

## Prediction of Core Loss Including Higher Harmonic Inductions Using Two Symmetrical AC Minor Loops

Derac Son

Han Nam University, Ojung Dong 133, Daejeon 306-791, Korea

(Received 16 December 2002)

For the induction motor and inverter type motor design, prediction and analysis of core loss including higher harmonics have been studied. In this work, we have generated two symmetrical ac minor loop in the fundamental hysteresis loop whose positions are zero induction region and saturation induction region, and we could predict core loss including higher harmonics inductions. using the following modified superposition principle;  $P_c(B_o, f_o, B_h, nf_o) = P_c(B_o, f_o) + (n-1)[k_1(B_o)P_{cL}(B_h, nf_o) + (1-k_1(B_o))P_{cH}(B_h, nf_o)]$ . Using this equation we could also analyze core losses including higher harmonic induction under different maximum magnetic induction, different amplitude of higher harmonic induction with different harmonic frequencies.

**Key words :** core loss, higher harmonic induction, electrical steel, induction motor.

### 1. Introduction

Measurement and analysis of core loss including higher harmonics have been studied for high efficiency induction motor design [1-3], and they become more important in inverter type motor design [4-7]. Theoretical analysis based on the hysteresis loss, dynamic loss, and excess loss [8], and numerical calculation using Preisach model and neural network [9-12] have been studied. But theoretical and numerical prediction of core loss including higher harmonics are still difficult and restricted in certain limit for example higher harmonic frequency range and maximum induction range.

For the analysis of core loss including higher harmonics, superposition principle was employed [2, 13], i.e. core loss including higher harmonics  $P_c(B_o, f_o, B_h, nf_o)$  is sum of the core loss of the fundamental harmonic component  $P_c(B_o, f_o)$  and the core loss of the higher harmonics component  $P_c(B_h, nf_o)$ . but this superposition principle was only agreed to the experimental data in low magnetic induction range.

To explain this problem, one ac minor loop is generated over laid to the fundamental hysteresis loop, and the position of the ac minor loop in fundamental hysteresis

loop was controlled using the phase angle of one period of the higher harmonic frequency relative to the fundamental wave. From this core loss measurement, we proposed a modified superposition principle [14].

In the present work, we have generated only two symmetrical ac minor loops over laid to the fundamental hysteresis loop, whose positions are zero induction region and saturation induction region, and we can predict core loss including higher harmonics inductions using the modified superposition principle.

### 2. Construction of Measuring System

Core loss measurement under desired waveform of the magnetic induction, an arbitrary waveform synthesizer and B-feedback system are necessary. For the generation of desired magnetic induction waveform, we can calculate the secondary induced voltage waveform, and the voltage waveform can be synthesized by the arbitrary waveform synthesizer, and secondary induced voltage can then be controlled to be the same as the synthesized voltage waveform using the B-feedback system. For the sample magnetization, double yoke type single sheet tester of which sample size is 8 cm × 8 cm was used.

For the digitization of the secondary induced voltage and the voltage across the shunt resistor which is connected to the primary winding serially to measure the magnetic

\*Corresponding author: Tel: +82-42-629-7512, e-mail: deracson@mail.hannam.ac.kr

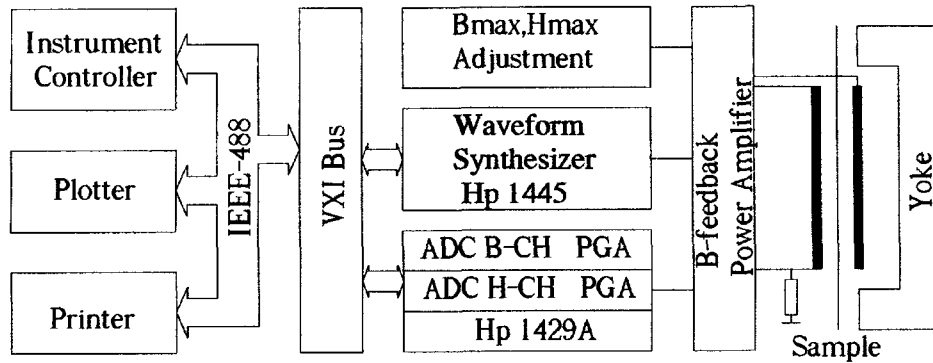

Fig. 1. Schematic diagram of measuring system for core loss measurement including higher harmonic induction.

field strength, a 12-bit two-channel transient recorder with maximum sampling speed of 20 Msamplings/s and memory size of 4 kwords per channel was used. Fig. 1 show a block diagram of the constructed core loss measuring system.

### 3. Experimental Results

Fig. 2 shows one period of ac minor loop whose higher harmonic frequency ( $f_h$ ) is  $23f_o$  ( $f_o=60$  Hz) and harmonic induction is 0.15 T which are located on the different position of the fundamental hysteresis loop whose frequency is 60 Hz and maximum magnetic induction is 1.5 T.

We can see that ac minor loop shapes are different when their position relative to the fundamental hysteresis loop is different.

Fig. 3 shows the change of core loss depending on the position of ac minor loop of different amplitude of the higher harmonic induction. When the higher harmonic amplitude is very small, the core loss was not changed regardless of the position of the minor loop. However the higher harmonic amplitude was increased, the core loss was increased not only depending on the harmonic amplitude but also the position of the minor loop. When the maximum magnetic induction  $B_{max}$  is 1 T, the core loss was not changed depending on the position of ac

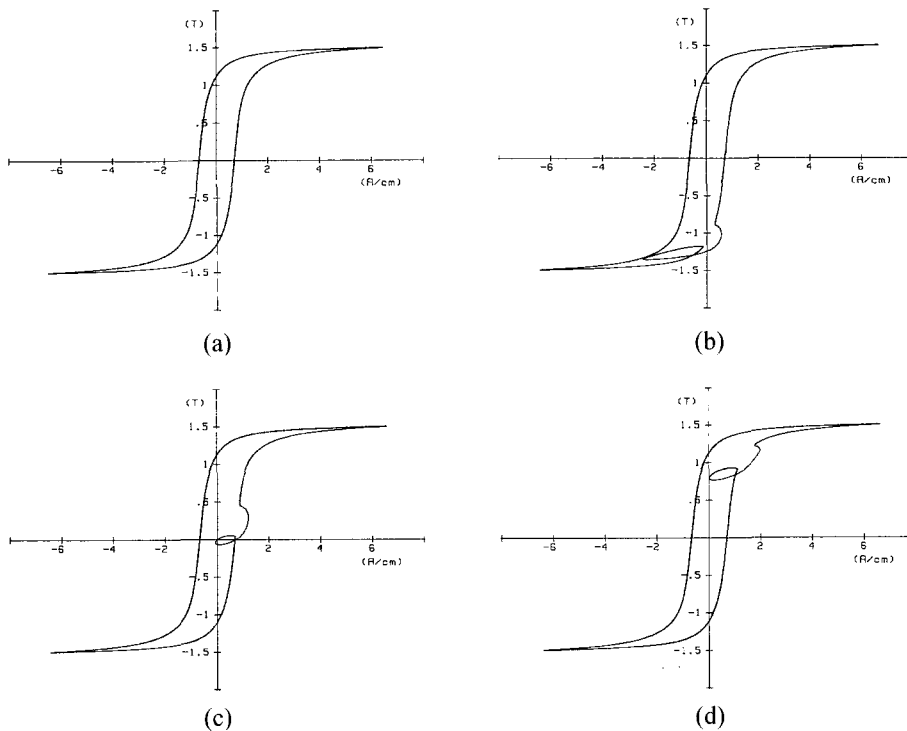
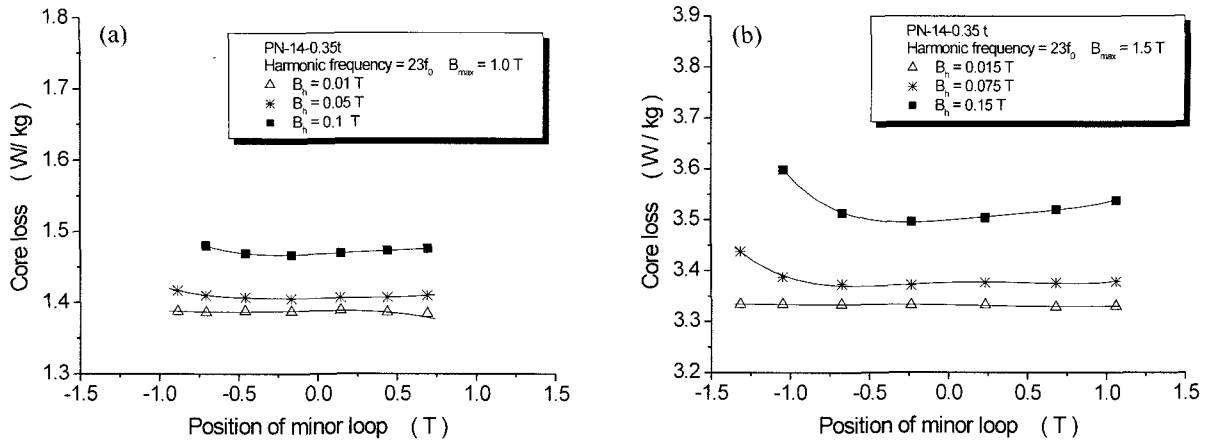

Fig. 2. Ac minor loop shapes depending on the position of minor loop relative to the major hysteresis loop of non-oriented electrical steel sheet at fundamental frequency of 60 Hz and higher harmonic frequency of  $23f_o$ , (a) without harmonics, (b) to (d) harmonic amplitude of 0.15 T respectively.



**Fig. 3.** Core loss with harmonic frequency  $23f_0$  depending on the position of ac minor loop at maximum magnetic induction of 1.0 T (a) and of 1.5 T (b) respectively.

minor loop, but maximum magnetic induction  $B_{max}$  is 1.5 T and harmonic induction amplitude becomes high, core losses were strongly changed depending on the position of ac minor loop. From this experimental results, we can suppose that ac minor loop in high induction region of major hysteresis loop, irreversible magnetization rotation, and zero induction region of major hysteresis loop, irreversible domain wall movement may be important role in the increasing of core loss. If we want to analyze and predict core loss including higher harmonics, we must take into account above magnetization processes, and it is

not so easy to predict core loss including higher harmonic induction theoretically or numerically.

Superposition principle used for the analysis of core loss as follows;

$$P_c(B_o, f_o, B_h, nf_o) = P_c(B_o, f_o) + (n-1) P_c(B_h, nf_o) \quad (1)$$

where  $P_c(B_h, nf_o)$ , which was measured only demagnetized state, was used, but  $P_c(B_h, nf_o)$  value is actually strongly depends on the position of ac minor loop relative to the major hysteresis loop as shown in Fig. 2. To predict

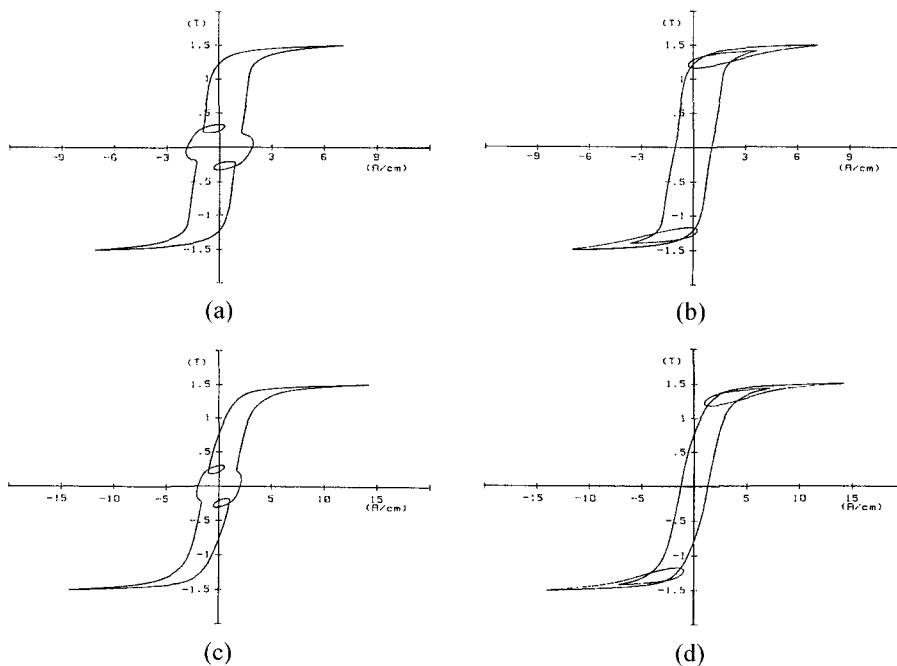

**Fig. 4.** Generation of two symmetrical ac minor loop in zero induction region (a) and (c), and saturation induction region (b) and (d) of the fundamental hysteresis loop, which were magnetized in the rolling direction (a) and (b), and perpendicular to the rolling direction (c) and (d).

core loss due to the higher harmonics, superposition principle should be changed as follows;

$$P_c(B_o, f_o, B_h, nf_o) = P_c(B_o, f_o) + \sum_1^{n-1} P_c(B_p, B_h, nf_o) \quad (2)$$

where  $B_p$  is position of ac minor loops, but all components of  $\sum_1^{n-1} P_c(B_p, B_h, nf_o)$  are difficult to measure. We proposed a modified superposition principle as follows

$$P_c(B_o, f_o, B_h, nf_o) = P_c(B_o, f_o) + (n-1) [k_1(B_o)P_{cL}(B_h, nf_o) + k_2(B_o)P_{cH}(B_h, nf_o)] \quad (3)$$

where  $P_{cL}(B_h, nf_o)$  is the core loss of the ac minor loop of which position is only zero induction region of the fundamental hysteresis loop,  $P_{cH}(B_h, nf_o)$  is the core loss of ac minor loop of which position is only saturation induction region of the fundamental hysteresis loop, and  $k_2(B_o) = 1 - k_1(B_o)$  is a function of only maximum magnetic induction  $B_o$  of the fundamental harmonic induction. For the measurement of  $P_{cL}(B_h, nf_o)$  and  $P_{cH}(B_h, nf_o)$ , we generated two symmetrical ac minor loop as shown in

Fig. 4. because hysteresis loop should be symmetry to obtain better measuring uncertainty in high induction region. Fig. 5 shows the comparison between the core loss calculated using Eq. (3) and measured core loss for the different maximum magnetic induction, different amplitude of higher harmonic induction with harmonic frequency ranging from  $15f_o$  to  $35f_o$ , and the parallel and perpendicular to the rolling direction of non-oriented electrical steel, where  $k_1(B_o)$  was obtained by least square method.  $k_2(B_o)$  values which were measured under different magnetic induction was plotted in Fig. 6. Fig. 6-(a) shows  $k_2(B_o)$  values measured in the rolling direction and Fig. 6-(b) for the perpendicular to the rolling direction. In Fig. 6-(a), when magnetic induction is lower than 1 T,  $k_2(B_o) = 0$  and this means that only  $P_{cL}(B_h, nf_o)$  contributes to the core loss increment due to the higher harmonic induction, and we could explain our early work [13]. In case of magnetizing direction is perpendicular to the rolling direction,  $k_2(B_o)$  values increase gradually vs. magnetic induction, and this means core loss of ac minor

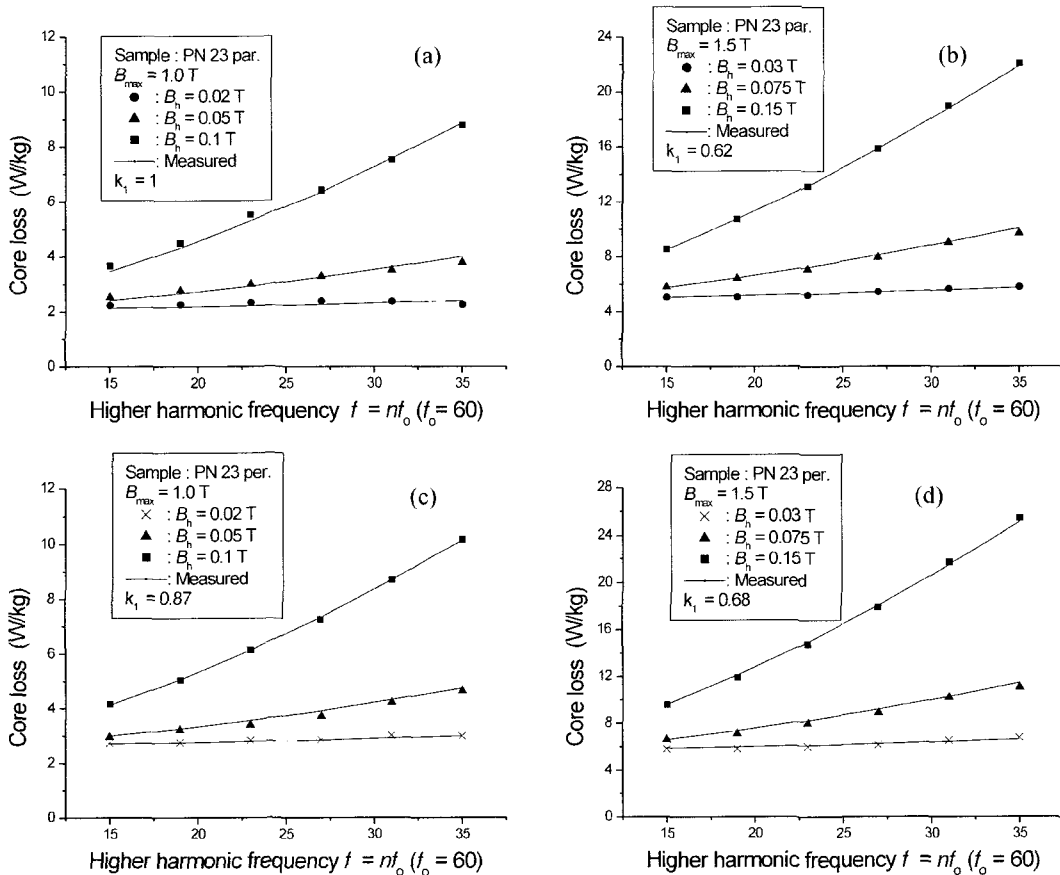

**Fig. 5.** Core loss depending on the higher harmonic frequencies of which harmonic amplitude are 2%, 5% and 10% of maximum magnetic induction 1.0 T (a) and (c), 1.5 T (b) and (d), and sample was were magnetized in the rolling direction (a) and (b), and perpendicular to the rolling direction (c) and (d); symbols (■, ▲, ●) obtained using equation (2), continuous curves (—) as measured.

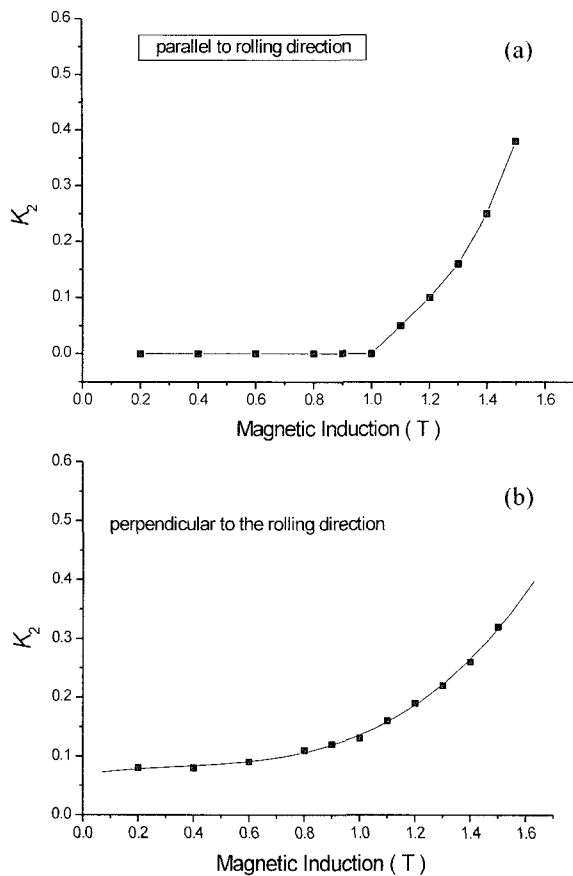

**Fig. 6.** Plotting of  $k_2$  vs. magnetic induction measured in the rolling direction (a) and perpendicular to the rolling direction (b).

loop originate from irreversible magnetization rotation contribute to the whole magnetic induction range.

We can see that various condition of higher harmonic induction, core losses could be calculate using Eq. (3) are fairly good agreement with experimental results, this means, modified superposition principle suggested in this work could be useful for the analysis and prediction of core loss including higher harmonics.

#### 4. Conclusion

For the analysis and prediction of the core loss including higher harmonic induction, we have generated only two ac minor loops are generated over laid to the fundamental hysteresis loop, and the core losses depending on

the harmonic amplitude and the position of ac minor loop were studied in this work. From this work, we have suggested a following modified superposition principle.

$$P_c(B_o, f_o, B_h, nf_o) = P_c(B_o, f_o) + (n-1)[k_1(B_o) P_{cl}(B_h, nf_o) + (1-k_1(B_o)) P_{ch}(B_h, nf_o)]$$

Using this equation we could predict core losses including higher harmonic induction under different maximum magnetic induction, different amplitude of higher harmonic induction with different harmonic frequencies, and different direction to the rolling direction for non-oriented electrical steel.

#### Acknowledgements

This work was partially supported by Korea Science and Engineering Foundation through the Research Center for Advanced Magnetic Materials.

#### References

- [1] H. L. Schenk and F. J. Young, IEEE Trans. on Magn. **MAG-17**, 3385 (1981).
- [2] T. Sasaki, et al., IEEE Translation J. on Magn. in Japan **7**, 64 (1992).
- [3] D. Son, IEEE Trans. on Magn. **MAG-35**, 3931 (1999).
- [4] A. Boglietti, et al., IEEE Trans. on Magn. **MAG-33**, 4002 (1997).
- [5] A. J. Moses and N. Tutkun, IEEE Trans. on Magn. **MAG-33**, 3763 (1997).
- [6] C. Cester and A. Kedous-Lebouc, IEEE Trans. on Magn. **MAG-33**, 3766 (1997).
- [7] S. Takada, et al., IEEE Trans. on Magn. **MAG-33**, 3760 (1997).
- [8] F. Fiorillo and A. Novikov, IEEE Trans. on Magn. **MAG-26**, 2559 (1990).
- [9] J. C. Gyselink, et al., IEEE Trans. on Magn. **MAG-34**, 3876 (1998).
- [10] N. Sadowski, et al., IEEE Trans. on Magn. **MAG-36**, 1923 (2000).
- [11] J. C. Gyselink, et al., IEEE Trans. on Magn. **MAG-36**, 856 (2000).
- [12] A. Salvini and C. Coltelli, IEEE Trans. on Magn. **MAG-37**, 3313 (2001).
- [13] D. Son, J. D. Sievert, and Y. Cho, J. of Magn. and Magn. Mat. **160**, 65 (1996).
- [14] C. Cho, D. Son, and Y. Cho, J. of Magnetics **6**, 66 (2001).