

Reduction of Tooth Harmonic in Fractional-Slot Concentrated-Winding Permanent-Magnet Machines Using New Stator Design

Mengmeng Wu^{1,2}, Wenxiang Zhao^{1,2*}, Jinghua Ji^{1,2}, Junqiang Zheng^{1,2}, and Jianhua Luo^{1,2}

¹School of Electrical and Information Engineering, Jiangsu University, Zhenjiang 212013, China

²Jiangsu Key Laboratory of Drive and Intelligent Control for Electric Vehicle, Zhenjiang 212013, China

(Received 6 September 2017, Received in final form 2 May 2018, Accepted 3 May 2018)

Fractional-slot concentrated windings (FSCWs) are characterized with many advantages. However, their magnetic fields have rich space harmonics. These harmonics, especially tooth harmonics, have negative effect on machine performances. This paper proposes a new method to reduce the tooth harmonics in FSCW permanent-magnet (PM) machine, in which the magnetic distribution in air-gap will be affected by winding span radian. Also, a new stator structure is designed on the method. By using the new stator design, each order tooth harmonic can be reduced significantly and the working harmonic can also be increased slightly. Simultaneously, the unbalanced radial magnetic force can be significantly weakened. The basic principle of tooth harmonic reduction method can be analyzed by using the stator structure of the FSCW machine with single layer windings. Then, a three phase 18-slot/16-pole FSCW machine with double layer windings is newly designed, which can effectively weaken the tooth harmonic components of FSCW machines. It is shown that, under the fixed electrical and geometrical constrains, the designed FSCW machine has better performances, such as loss, vibration and noise, than the conventional ones.

Keywords : permanent-magnet machine, fractional-slot concentrated windings, space harmonics, tooth harmonic reduction, eddy-current loss, vibration and noise

1. Introduction

Nowadays, permanent-magnet (PM) machine having fractional-slot concentrated-winding (FSCW) have attracted increased attention for many applications, owing to their lots of merits such as high efficiency, high power density, high filling factor, low cogging torque, cost-effectiveness, short end-winding length, and good field-weakening capability [1-4]. Their slot/pole-combination is various [5-7], and different combinations can be chosen based on different application requirements. However, these FSCW-PM machines suffer from rich space harmonics in the magnetic field, which has negative effects on electromagnetic performances [8, 9]. In PM machines, it is well-known that only specific stator magnetomotive force (MMF) harmonic, namely working harmonic, interacts with the PM magnetic fields to produce continuous electromagnetic torque [10]. However, other harmonics with

different rotor speeds will deteriorate machine performances, such as generating eddy current (EC) loss in PMs, localized core saturation, additional core losses in rotor and stator, electromagnetic noise and mechanical vibration of whole machine [11-19]. These harmonics, especially the MMF sub-harmonic and tooth harmonic components will cause flux variation in the air-gap. Then, the machine loss and vibration will be greatly increased. In fact, the decrease of MMF harmonic components is helpful to reduce the EC loss in PMs and the vibration caused by tooth harmonic components. Therefore, it has very significant effects on PM heat dissipation.

In order to take full advantages of FSCW-PM machines, several methods were proposed to reduce the lower and higher order stator MMF spatial harmonic components. Farnasiero *et al.* [20, 21] put forward a promising technique to reduce the amplitude of the sub-harmonic components by using multi-layer tooth concentrated windings and shifting the winding systems by a specific number of slots. This winding structure can change the winding factors of MMF, which will eliminate the sub-harmonics in air-gap flux density. As a result, the reduction of sub-

©The Korean Magnetism Society. All rights reserved.

*Corresponding author: Tel: +86-511-88778773

Fax: +86-511-88778773, e-mail: zwx@ujs.edu.cn

harmonic is more than 60 % from double layers type to four layers type. In addition, Chen *et al.* [22-24] designed multiple three-phase concentrated windings. By using this winding structure, the fundamental winding factor is improved, and the detrimental effects of lower and higher order MMF harmonics are reduced without sacrificing the advantages of concentrated windings. However, in order to achieve the same effect in the conventional machine, the two sets of three phase windings are required. Since each three phase winding is independently controlled, the multiple three phase winding structure can reduce the value analysis rating of each windings and inverter, thus providing redundancy and fault tolerance. Then, Ahmed *et al.* [25] proposed a novel stator structure with Star/Delta winding connection. MMF can be dissolved into various rotation waves. The phase current has phase difference by controlling two sets of three phase windings. Then, the MMF components produced by two sets of windings in the air gap have opposite rotate direction and can be artfully offset, which will effectively eliminate partial MMF harmonic components. Meanwhile, the six phase rectification can be carried out to significantly reduce the current ripple factor and further improve the rectification effects. So, conventional three phase terminals can be preserved in this case by connecting the two three phase sets in a combined Star/Delta configuration. Also, this concept can be extended to five phase windings by using a combined Star/Pentagon connection. A 2-D analytical 12-slots/10-pole model was proposed by Gerling *et al.* [26] to reduce the losses, noise and vibrations. The 1st, 7th, and 17th order harmonics affect the loss and vibration noise in the 12-slot/10-pole motor, and the 7th and 17th order harmonics are tooth harmonics. Assuming the slot is z and pole pair is p , the $(kz \pm p)$ th order harmonics are tooth harmonics. The tooth harmonics and work harmonic have identical distribution factor and winding factor. Gerling *et al.* succeeded in reducing the first order MMF harmonic component by using the unequal turns per coil-side and inserting the magnetic flux-barriers in stator yoke. Nonetheless, in order to satisfy the technology requirement, the difference of two side turns in a coil should only be 1. The investigation on the winding factors of MMF harmonic shows that if the ratio to two sides in a coil is n_1/n_2 , whose value is between 80 % and 90 %, e.g., $n_1/n_2 = 6/7, 7/8, 8/9$, and so on, the first sub-harmonic of the proposed winding type can be reduced more than 90 %. In [27, 28], Wang *et al.* presented a new model to reduce copper loss and usage, increase power and torque density, and improve energy efficiency by doubling the number of stator slots and using two sets of winding

systems. By varying the 9-slot/8-pole machine to 18-slot/8-pole machine and changing its former phase rectification from three to six, the 1st, 5th, 7th, 11th, and 13th order harmonic components will be eliminated. Both machines are designed under the same electrical and geometrical limits. Whereas, with the increase of slot number, the winding pitch will vary from 1 to 2 and the distribution factor will also decrease. In addition, more harmonics can be scaled down by enlarging the slot number to 36. However, their main shortcoming is that the tooth harmonic component especially the $(z-p)$ th order harmonic component cannot be reduced. And, it is known that the ν order harmonic frequency of main magnetic field is $\nu w_1/p$ and the 1st order tooth harmonic frequency is w_1 . It has been known that the interaction between these harmonics will cause machine vibration. Therefore, the decrease of the tooth harmonics in winding MMF can be beneficial to reduce machine vibration. Gerling *et al.* investigated the influence of the stator slot opening on the characteristics of concentrated windings in [29]. Also, it was shown that the components of the working wave and harmonics are evaluated in dependency of the stator slot opening. However, only the slot opening effects on tooth harmonics are investigated. The designed winding structure, which can reduce tooth harmonics, is not given in the further study.

In this paper, considering the demerits above, first of all, several works are carried out to calculate the winding MMF of the conventional three phase machine at working condition.

The stator structure of the single layer FSCW machine can be designed by optimizing its armature teeth angles. This machine can effectively weaken the tooth harmonic of single layer windings. Furthermore, the auxiliary teeth are creatively added between phases of FSCW. In the proposed 18-slot/16-pole machine, six auxiliary teeth are added between phases and the stator teeth angles across circumference are accurately calculated. In Section II, the method will be detailed illustrated on how to reduce tooth harmonic components by changing stator structure of the single layer machine. Then, the stator tooth parameters of the proposed 18-slot/16-pole machine with double layer windings will be elaborately calculated. Also, the winding harmonic components in the air gap will be investigated. In Section III, both conventional and proposed 18-slot/16-pole machine will be designed to validate new stator structure, which can greatly reduce tooth harmonics. Then, vibration and noise of the newly designed machine will be discussed. Finally, the conclusion will be drawn in Section IV based on the formal analysis.

2. Theoretical Calculation and Design of New Stators

The MMF in air gap can be scaled down by changing stator structure and winding connection type, which are affected by winding layers. In this section, the stator structure effects on tooth harmonic reduction in conventional machines with single layer (SL) windings, is investigated. By using this method, the stator structure of a three phase 18-slot/16-pole FSCW machine with double layer (DL) windings will be changed and its corresponding parameters will be further calculated.

There exists a 120 electrical degree between two phases in traditional three phase machines. When symmetry three phase current is added into windings, the synthetic MMF will include positive and negative order components. Also, either positive or negative order components will be zero in symmetry windings. Therefore, the every order harmonic will compose a rounded rotary MMF. When the three phase current expressed by (1) is added into a Z -slot/ $2p$ -pole machine:

$$\begin{cases} i_A = \sqrt{2}I \cos(\omega t) \\ i_B = \sqrt{2}I \cos\left(\omega t - \frac{2\pi}{3}\right) \\ i_C = \sqrt{2}I \cos\left(\omega t - \frac{4\pi}{3}\right) \end{cases} \quad (1)$$

where I is the virtual value of current and ω is the angular frequency of current. Therefore, the synthetic MMF produced by windings can be expressed as:

$$\begin{aligned} F(x, t) = & \sum_{v=1}^{\infty} \frac{3\sqrt{2}\omega I}{\pi v} k_{wv+} \cos\left(\omega t - vx + v\frac{\theta_y}{2} + v\varphi\right) \\ & + \sum_{v=1}^{\infty} \frac{3\sqrt{2}\omega I}{\pi v} k_{wv-} \cos\left(\omega t - vx + v\frac{\theta_y}{2} + v\varphi\right) \end{aligned} \quad (2)$$

where k_{wv} , ω , v , θ_y , and φ is winding factor, harmonic order, crossing angle of the stator tooth and angle lagging behind the origin.

Therefore, the each order harmonic component produced by windings is proportional to the MMF amplitude and inversely proportional to the harmonic order. Thus, the every order harmonic can be expressed by the percentage of the fundamental harmonic.

$$F_v (\%) = \frac{k_{sv} k_{pv} k_{dv}}{k_{sv} k_{pv} k_{dv}} \frac{p}{v} \times 100 \quad (3)$$

where k_{sv} , k_{pv} and k_{dv} are winding rabbit factor, distribution factor and pitch factor, respectively, and their

product is winding factor. It can be seen that the ratio to each order and fundamental harmonic is related to winding factor of the corresponding order harmonic. Simultaneously, the tooth harmonics include $(z-p)^{th}$, $(z+p)^{th}$, and $(2z-p)^{th}$ orders have the same winding factor with fundamental harmonic. However, they have negative effects on machine operation and particularly the $(z-p)^{th}$ harmonic even rotates opposite to the working harmonic, which will significantly deteriorate the performances of machine. So, the new design of stator structures will be based on reducing $(z-p)^{th}$ order harmonic.

2.1. Tooth Harmonics in Single Layer Windings Machines

The single layer FSCW-PM machines are widely applied owing to their superior fault tolerance capability. Their one phase coils are concentrated and wound on adjacent teeth. Assuming the slot opening effects on MMF are neglected, the winding factor will equal the pitch factor because the distribution factor of single layer windings is 1. By using Fourier series function, the MMF distribution for the Z -slot/ $2p$ -pole FSCW-PM machine with SL windings can be expressed as:

$$\begin{cases} F_v(x, t) = \sum \frac{3}{2} I_m F_{\phi v} \sin(\omega t - vx) \\ F_{\phi v} = \frac{2N_c}{\pi v} N_{\phi} I_c k_{wv} \\ k_{wv} = k_{sv} k_{pv} k_{dv} = \sin\left(v\frac{\pi}{Z}\right) \end{cases} \quad (4)$$

where $F_{\phi v}$ is the amplitude of the v^{th} MMF harmonic, I_c is the phase current effective value, $N_c N_{\phi}$ is the number of turns per coil, ω is the angular frequency of motor, and v is the MMF harmonic order. In addition, the multiple of 3th order MMF synthetic vector is zero in a three phase machine. The principle of pitch factor is shown in Fig. 1(a), which presents the conventional symmetrical structure. The angle between two coils is 2θ , and the pitch

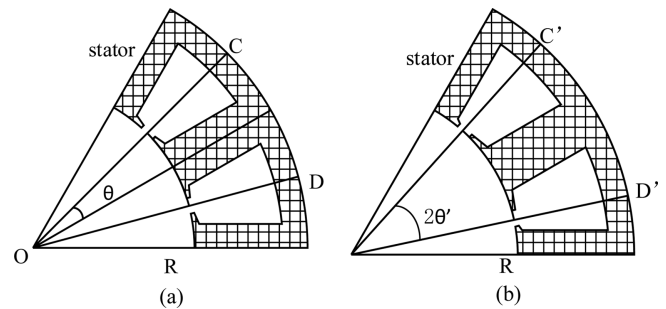

Fig. 1. Schematic diagram of pitch factor in different tooth structures (a) Conventional one. (b) Proposed one.

factor can be expressed as:

$$k_{pv} = \sin v\theta = \frac{2R \sin v\theta}{2R} = \frac{CD}{2R} \quad (5)$$

By changing the angle between two coils, the new stator structure will reduce tooth harmonic components, as shown in Fig. 2(b). The crossing mechanical angle of one coil of the newly designed stator structure is from 2θ to $2\theta'$. Simultaneously, only the slot opening position is changed while the stator tooth width is fixed.

Therefore, the harmonic spectrum of the proposed Z-slot/2p-pole machine can be expressed as:

$$F_{\Phi_v}(p.u.) = \left| \frac{p \sin v \frac{\theta_y}{2}}{v \sin p \frac{\theta_y}{2}} \right| \quad (6)$$

where $\theta_y = 2\theta'$ and it is the angle between two sided coils of armature teeth in the new structure. With the increase of harmonic order, the ratio to its corresponding harmonic and fundamental harmonic produced by winding will decrease, which will further weaken the effects on machine performance. Therefore, it is important to investigate the effective decrease of low order tooth harmonic. So, the ratio of $(Z-p)^{\text{th}}$ harmonic component between armature teeth to fundamental harmonic can be expressed as:

$$\left| \frac{F_{\Phi(Z-p)}}{F_{\Phi p}} \right| = \left| \frac{\frac{2N_c}{(Z-p)\pi} N_\phi I_c k_w(z-p)}{\frac{2N_c}{p\pi} N_\phi I_c k_{wp}} \right| = \left| \frac{p \sin(Z-p)\theta'}{(z-p) \sin p\theta'} \right| \quad (7)$$

$$0 \leq \theta' \leq \frac{2\pi}{z}$$

When (7) is minimum, the stator structure can be

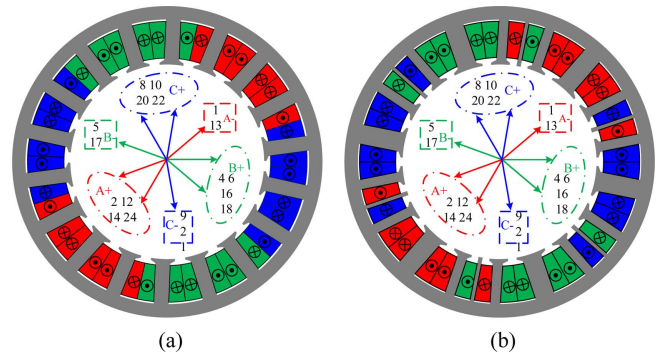

Fig. 2. (Color online) Winding arrangement and stator structure in 18-slot/16-pole DL machines. (a) Conventional one. (b) Proposed one.

designed by adjusting the stator slot position without changing stator tooth width. It is observed that the corresponding high order tooth harmonic components are all effectively reduced. Furthermore, the decrease of tooth harmonic in double layer windings will be analyzed. Actually, there are no fault tolerance teeth in double layer windings and their distribution factors are complex, thus the variation of stator structure is slightly different with the change of slot/pole combination. And this paper will investigate double layer 18-slot/16-pole machine.

2.2. Tooth Harmonics in Double Layer Windings Machines

In the 18-slot/16-pole machine having double layer windings, all the stator teeth will wound with windings, which are presented in Fig. 2. It is difficult to change the slot position in these machines having double layer windings. If the angle θ of one tooth is increased, the pitch factor of the corresponding coil will be enlarged, but the angle of its adjacent two teeth and the coil pitch factor will also be reduced. Thus the winding factor of per phase

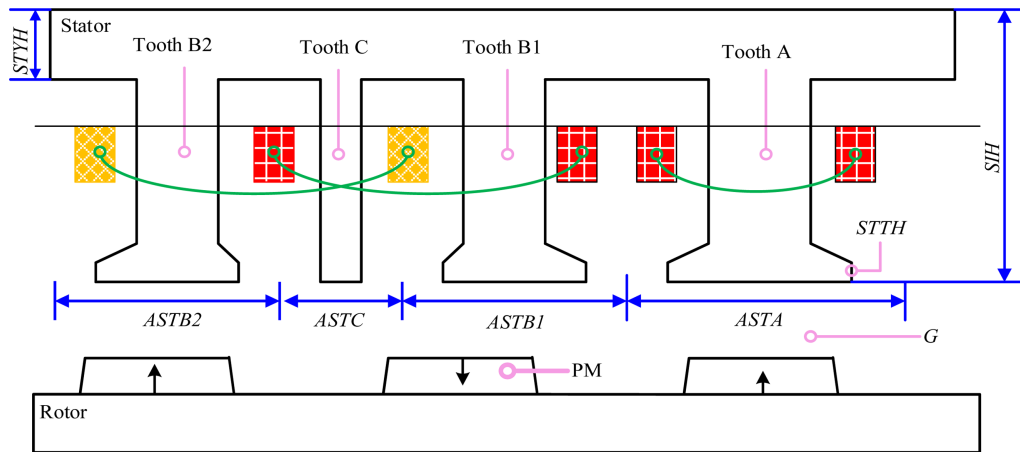

Fig. 3. (Color online) Schematic of proposed 18-slot/16-pole machine parameters.

cannot be only changed by varying stator opening position. In order to solve this problem, a new stator structure is proposed, in which six auxiliary teeth are adopted among phases. The stator is divided into six parts and the detailed stator parameters are illustrated in Fig. 3. The new structure includes four kinds of stator teeth. Tooth A is the conventional symmetric tooth, and tooth C is the new added auxiliary tooth. Moreover, teeth B1 and B2 are the combination of the symmetric and asymmetric tooth. It is noted that the concentrated windings is transferred to the distribution windings on teeth B and C, whose pitch is 2 per coil at unction between phases. By optimizing the four stator teeth parameters, the high order tooth harmonic components can be scaled down with no sacrifice of merits in FSCW-PM machines. However, it should be noted that the calculation method is different from the aforementioned analysis. Namely, apart from the winding pitch, the distribution factor effects on air-gap MMF should be considered.

Assuming the angles of stator A and C are $2a$ and $2c$, the angles of stator B1 and B2 are both $a + b$, the distribution factor and pitch factor of the proposed 18-slot/16-pole machine can be calculated. It can be obtained by guaranteeing the maximum pitch factor of each coil:

$$\begin{cases} k_{pc} = \sin 8 \frac{2a}{2} \\ 12a + 12(a + b) + 12c = 2\pi \\ k_{p8} = \sin 8 \frac{4a + 2b + 8c}{3} \\ k_{d8} = \frac{2 \cos(a + b + 4c)}{3} \end{cases} \quad (8)$$

where k_{pc} is the pitch factor of each coil related to the 8 order harmonic component, k_{p8} is the pitch factor of each phase, and k_{d8} is the distribution factor related to the 8th order harmonic component. In order to decrease the (z - p)th order harmonic component and avoid sacrifice of torque, the winding factor of the working harmonic should be fixed. By using the slot potential star map, the each stator tooth electrical angle of the proposed 18-slot/16-pole machine having six auxiliary teeth can be calculated, which is associated with the working harmonic. Furthermore, the winding factors related to the 8th and 10th harmonics are also derived. It can be expressed as:

$$\begin{cases} k_{w8} = k_{q8} \times k_{p8} = \frac{2 \times \left| \cos \left(8 \times \frac{360 - 12(a + b) - 12c}{6} \right) \right| + 1}{3} \times \sin \left(8 \frac{2a}{2} \right) \\ k_{w10} = k_{q10} \times k_{p10} = \frac{2 \times \left| \cos \left(10 \times \frac{360 - 12(a + b) - 12c}{6} \right) \right| + 1}{3} \times \sin \left(10 \frac{2a}{2} \right) \end{cases} \quad (9)$$

In order to reduce the ratio to 10th harmonic and working harmonic, the working harmonic related to the largest pitch factor is ensured. So, the pitch factor of the corresponding working harmonic is 1. Also, the distribution factor related to the working harmonic should be also considered to achieve the maximum value. And then, the mechanical angle of three types of stator teeth can be calculated. Therefore, the three parameters, namely a , b and c can be expressed as:

$$\begin{cases} a = \pi / 16 \\ b = \pi / 48 \\ c = \pi / 48 \end{cases} \quad (10)$$

Therefore, the harmonic spectrum of the proposed 18-slot/16-pole machine can be approximately expressed as:

$$F_{\Phi v}(p.u.) = \frac{8 \times \frac{2 \times \left| \cos \left(\frac{\pi v}{8} \right) \right| + 1}{3} \times \sin \left(\frac{\pi v}{16} \right)}{v \times \frac{2 \times \left| \cos \left(\frac{8\pi}{8} \right) \right| + 1}{3} \times \sin \left(\frac{\pi}{2} \right)} = \frac{8 \sin \left(\frac{\pi v}{16} \right) \left(2 \times \left| \cos \left(\frac{\pi v}{8} \right) \right| + 1 \right)}{3v} \quad (11)$$

Since high order harmonics significantly affect the machine performance, only thirty order harmonics are investigated. In particular, when the harmonic order is 2th and 14th, the vector of the harmonic MMF of the coil group is shown in Fig. 4. In these two cases, the distribution factor is quite different from (11), thus further research should be carried out. Finally, by neglecting the slot opening and machine saturation effects on winding MMF, the harmonic spectrum responding to the 2th, and 14th order harmonic can be expressed as (12) after vector synthesis.

$$\begin{cases} F_{\Phi 2}(p.u.) = \frac{8k_{q2}k_{p2}}{2} = 4 \times \frac{0.258}{3} \sin \left(\frac{\pi}{8} \right) = 0.132 \\ F_{\Phi 14}(p.u.) = \frac{8k_{q14}k_{p14}}{14} = \frac{4}{7} \times \frac{0.999}{3} \sin \left(\frac{7\pi}{8} \right) = 0.0728 \end{cases} \quad (12)$$

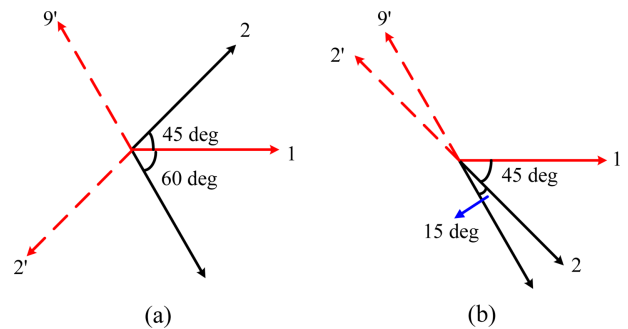

Fig. 4. (Color online) Schematic diagram of per phase distribution of proposed 18-slot/16-pole machine. (a) The 2th order harmonic. (b) The 14th order harmonic.

It is found that the ratio of 10th order tooth harmonic to fundamental harmonic decreases about 25.3 % by calculating the MMF harmonic components in the newly designed winding structure. In addition, with the increase of pitch factor, the fundamental harmonic will increase and the output torque will increase under identical electrical load.

Different from fault tolerant teeth in machines with single layer winding, which have no windings and their sizes can be changed optionally. In FSCW machine having double layer windings, the distributed factor and pitch factor should be considered when changing the ratio to tooth harmonic and fundamental harmonic. In order to decrease the ratio of $(z-p)$ th order harmonic to fundamental harmonic, the corresponding pitch factor of fundamental harmonic is changed to 1 and it may be the same with single layer windings. However, with the increase of pitch factor, the distributed factor of per phase windings will also vary under the same connection type. Therefore, the distributed factor of each order harmonic components should be independently investigated. Meanwhile, in order to ensure that the pitch factor of fundamental harmonic is 1, the auxiliary teeth are creatively added in this paper. However, this method should be based on the symmetrical phase to phase in whole circle, such as 9-slot/8-pole, 18-slot/16-pole, 36-slot/34-pole, etc. The method can be also used in multiphase machines, such as 8-slot/6-pole, 20-slot/18-pole, 20-slot/22-pole, etc.

3. Verification and Evaluation

3.1. Tooth harmonic weaken

By using finite element analysis (FEM), both 18-slot/16-pole FSCW-PM machines are investigated to verify the new design of the stator structure to reduce the tooth harmonics. In fact, considering the different stator struc-

Table 1. Design parameters of both machines.

Item and symbol	Conventional 18/16	Proposed 18/16
Output power P (kW)	12	12
Rotor speed n (r/min)	4300	4300
DC bus voltage U_{DC} (V)	380	380
Outer diameter of stator D_{so} (mm)	120	120
Inner diameter of stator D_{si} (mm)	75	75
Outer diameter of rotor D_{ro} (mm)	74	74
Air-gap length g (mm)	0.5	0.5
Axial length l (mm)	53	53
Thickness of PM h_{pm} (mm)	4.5	4.5
Depth of slot h_s (mm)	15	15
Number of phase m	3	3
Number of slots Z	18	24
Number of pole-pairs p	8	8
Slot open B_{s0} (mm)	2	2
Turns per phases N_c	19	19
Remanence of PM B_r (T)	1.28	1.28
PM material	NdFe40	NdFe40
Iron core lamination	B20AT1500	B20AT1500
Amplitude of the phase current I_{max} (A)	40	40
Tooth thickness (mm)	5.6	Tooth A 6.4 Tooth B 4.8 Tooth C 3
Average slot area S_{avg} (mm ²)	172	172
Space factor emb	0.7	0.7
Polar-arc coefficient of PM α_{pm}	0.8	0.8

tures, the windings are connected under the maximum winding factor. The parameters of the conventional and proposed machines are listed in Table 1. It can be noted that the added auxiliary teeth can satisfy the manufacture condition.

For a fair comparison, the conventional and proposed machines are designed with the same electrical and geometrical limits, including the same electrical current den-

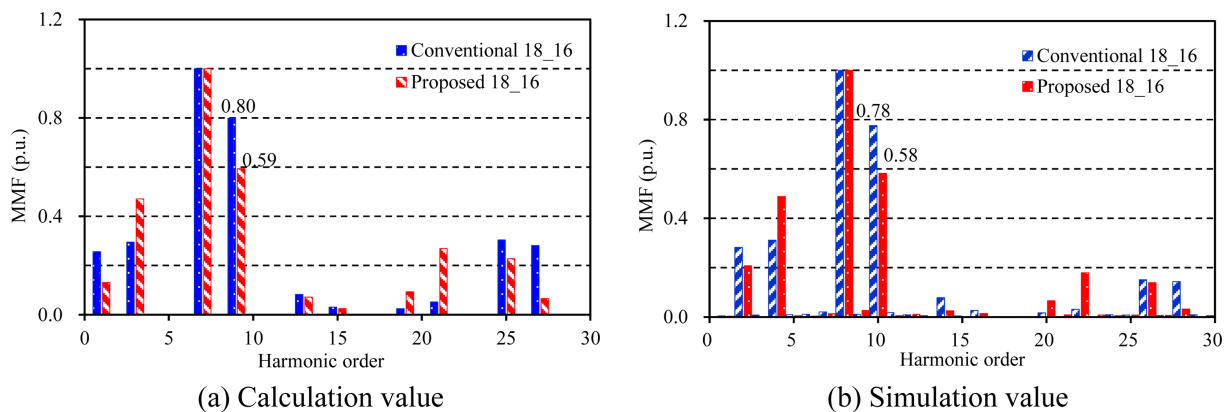

Fig. 5. (Color online) Armature field MMF winding harmonics of conventional and proposed machines. (a) Calculation value. (b) Simulation value.

sity, machine power and slot space-factor. Additionally, their rotor structures are fixed.

The spectrum analysis of conventional and improved 18-slot/16-pole machine is shown in Fig. 5(a). And, by using the air-gap flux density, the radical magnetic flux density in the air-gap of the machines can be calculated and its corresponding harmonics are analysed by using Fourier series function in Fig. 5(b). It can be observed from Fig. 5 that the ratio of tooth harmonic to working harmonic is significantly reduced from 0.78 to 0.58 in the proposed 18-slot/16-pole machine. Also, there exists a good agreement between theoretical analysis and FEM results. It is seen from Fig. 5(b) that the 10th, 26th, and 28th order harmonic components of the MMF are all reduced. Further observation reveals that the high order harmonics of the new machine winding, such as the 44th tooth harmonic is significantly decreased. Simultaneously, it should be emphasized that the low order harmonics in the proposed 18-slot/16-pole machine are scaled down.

The rated torque of both machines is investigated in Fig. 6. The phase current limits of the two machines are kept the same value of 40 Arms. And the proposed machine can slightly enhance the output torque with the same volume of both machines, which validates the former analysis and further highlights the superiority of the proposed machine. It is noted from Fig. 6 that the average torque is improved from 27.5 to 28.5 Nm and the cogging torque is increased from 0.5 Nm to 1 Nm. Although the torque ripple is relatively increased, the variation is insignificant and acceptable. The loss details at rated load of these two machines, obtained by 2D FE analysis, are compared in Fig. 7. It deserves attention that the copper loss is to maintain the same. Actually, the end winding length of improved machine is slightly longer than the conventional machine, thus the copper loss will be relatively increased. However, the PM eddy current loss is decreased from 57.7W to 39.8W and the iron loss is

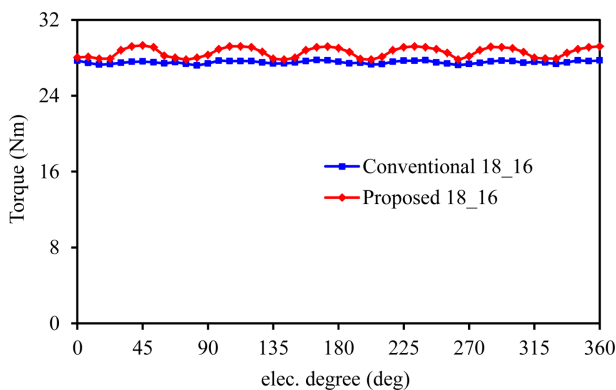

Fig. 6. (Color online) Comparison of rated torque.

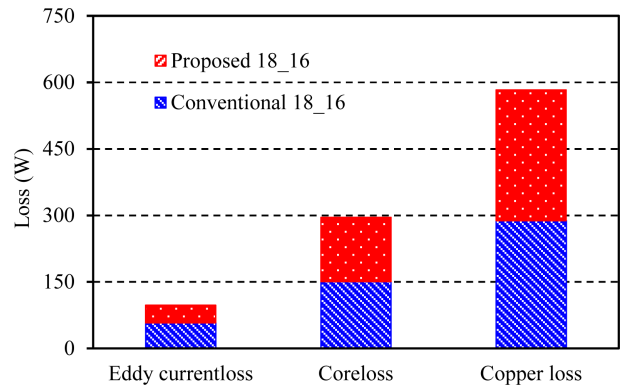

Fig. 7. (Color online) Loss details.

kept same. Therefore, the performance of the proposed machine will be improved and the operation temperature will be decreased compared with the conventional machine.

Figure 8 illustrates the value of self-inductance and mutual inductance of the both machines at the same current. Actually, the inductance of the proposed machine is larger than the conventional one. So, the armature reaction caused by the same armature current is larger, and the magnetic saturation of the stator core will be aggravated, which leads to the decrease of torque rising ability com-

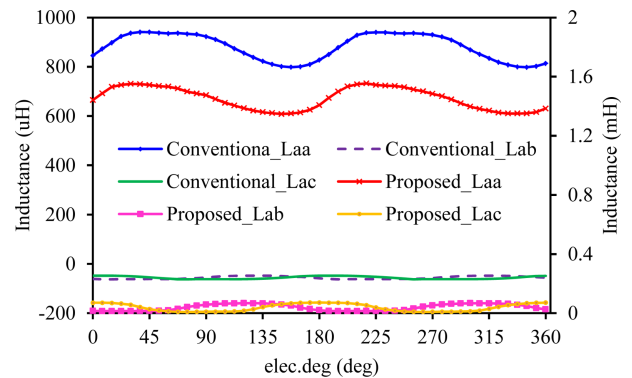

Fig. 8. (Color online) Comparison of self-inductance and mutual inductance.

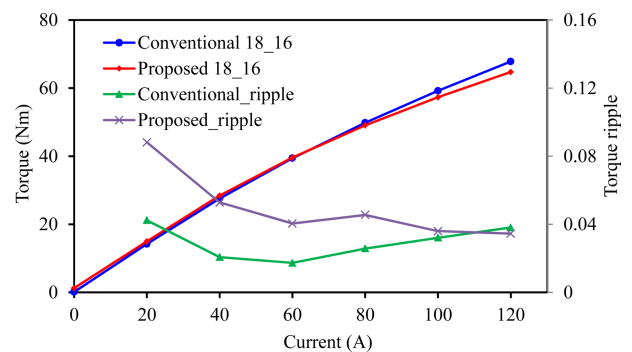
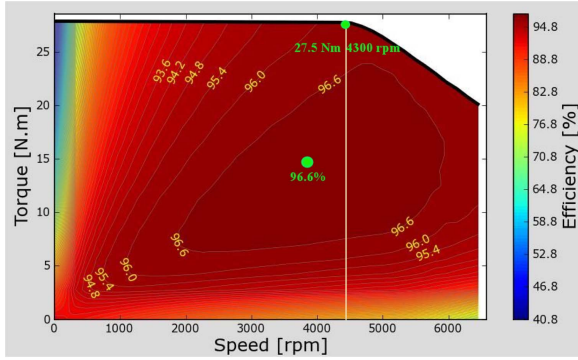
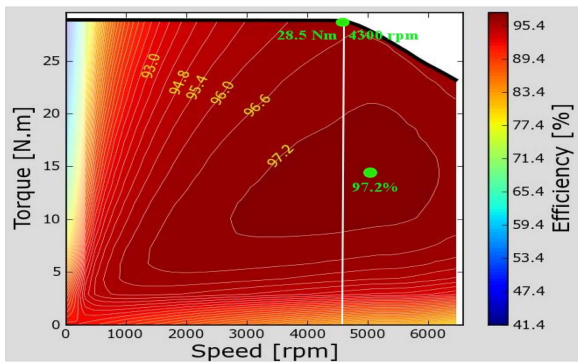

Fig. 9. (Color online) Torque and torque ripple with respect to current.



(a) Conventional one



(b) Proposed one

Fig. 10. (Color online) Efficiency map. (a) Conventional one. (b) Proposed one.

pared with the conventional machine. Therefore, the conventional machine can exhibit better overload capability. It is noted that the advantage of overload capability is insignificant. Fig. 9 shows that the two machines exhibit the minimum torque ripple at rated current.

The efficiency map of both machine are shown in Fig. 10. It can be found from Fig. 10 that the maximum efficiency of conventional machine reaches 96.6 % and its range of speed regulation is from 2000 to 5700 r/min. In the proposed machine, the efficiency is improved to 97.2 % and the range of speed regulation is from 2800 to 6100 r/min. If the proposed machine efficiency is 96.6 % simultaneously, the range of speed regulation is extended to 1300 to 6500 r/min which meets the requirement of wide range of speed regulation. Meanwhile, it is noted from Fig. 10 that the speed-torque curve of the proposed machine has smaller slope and its flux weaken capability is stronger.

3.2. Tooth Harmonic Effects on Machine Vibration and Noise

According to Maxwell stress equation, the radial electromagnetic force of unit area of stator tooth surface can be

expressed as:

$$\begin{aligned}
 f_r &= \frac{1}{2\mu_0} (B_r^2 - B_t^2) \approx \frac{1}{2\mu_0} B_r^2 \\
 &= \frac{1}{2\mu_0} (B_{R\delta} + B_{S\delta})^2 = \frac{1}{2\mu_0} B_{R\delta}^2 + \frac{1}{2\mu_0} B_{S\delta}^2 + \frac{1}{\mu_0} B_{R\delta} B_{S\delta} \\
 &= \frac{1}{2\mu_0} \left\{ \sum_{v_R} B_{Rm}^{v_R} \cos v_R (p_0 \theta - \omega t) \right. \\
 &\quad \left. + \sum_{k_Z=1}^{\infty} \sum_{v_R} B_{Rmk_Z}^{v_R} \cos [(v_R p_0 \pm k_Z Z_0) \theta - v_R \omega t] \right\}^2 \\
 &\quad + \frac{1}{2\mu_0} \left\{ \sum_{\mu} \sum_{v_S} B_{Sm}^{\mu, v_S} \cos (v_S p_0 \theta - \mu \omega t + \varphi^{\mu, v_S}) \right. \\
 &\quad \left. + \sum_{k_Z=1}^{\infty} \sum_{\mu} \sum_{v_S} B_{Smk_Z}^{\mu, v_S} \cos [(v_S p_0 \pm k_Z Z_0) \theta - \mu \omega t + \varphi^{\mu, v_S}] \right\}^2 \\
 &\quad + \frac{1}{\mu_0} \left\{ \sum_{v_R} B_{Rm}^{v_R} \cos v_R (p_0 \theta - \omega t) \right. \\
 &\quad \left. + \sum_{k_Z=1}^{\infty} \sum_{v_R} B_{Rmk_Z}^{v_R} \cos [(v_R p_0 \pm k_Z Z_0) \theta - v_R \omega t] \right\} \\
 &\quad \times \left\{ \sum_{\mu} \sum_{v_S} B_{Sm}^{\mu, v_S} \cos (v_S p_0 \theta - \mu \omega t + \varphi^{\mu, v_S}) \right. \\
 &\quad \left. + \sum_{k_Z=1}^{\infty} \sum_{\mu} \sum_{v_S} B_{Smk_Z}^{\mu, v_S} \cos [(v_S p_0 \pm k_Z Z_0) \theta - \mu \omega t + \varphi^{\mu, v_S}] \right\}
 \end{aligned} \tag{13}$$

where μ_0 is the permeability of the free space, B_r is the magnetic flux density in the normal direction, B_t is the magnetic flux density in the tangential direction, k_Z is tooth harmonic order, θ is the rotor mechanical angle, ω is the angular frequency of stator winding fundamental current, B_R is flux density of PM magnetic field and B_s is flux density of armature magnetic field. In addition, v_R can be expressed as $(2k-1)$ where the value of k can be fetched as 1, 2, 3, ...

Radial and tangential magnetic densities of two machines are compared in Fig. 11. It is found that radial flux density of both machines is larger than tangential magnetic density. Considering the torque is mostly produced by radial flux density, the radial force can be calculated by radial flux density according to (13) and the tangential magnetic density can be neglected.

The radial force density harmonics of two machines are shown in Fig. 11(b). The lowest harmonic order has dominant influence on vibration. Acoustic noise and the radial force density will reach a large value when machine stator pole synchronizes rotor pole. It is observed that the proposed 18-slot/16-pole machine can significantly reduce the 2nd order harmonic component. It is seen from Fig.

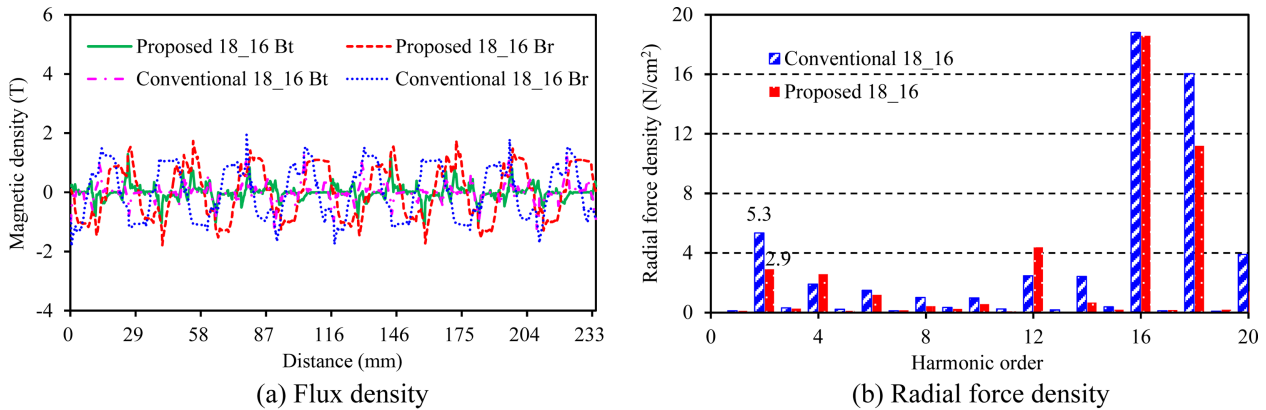

Fig. 11. (Color online) Flux density and harmonics of radial force density of both machines. (a) Flux density. (b) Radial force density.

11(b) that the 2nd order radial force density is decreased from 5.3 N/cm² to 2.9 N/cm². And then, the radial force density of both machines are predicted and analysed. The electromagnetic force of both machines at current 40 A is calculated. It should be noted that the stator teeth suffer from larger electromagnetic force than stator yoke. When the electromagnetic force is imported, the expanded structural response from natural modes can be computed. Fig. 12 shows that the stator teeth have significant deformation on two machines. Whereas, it is found that structural

response of the proposed 18-slot/16-pole machine has less vibration than the conventional one at 1200 Hz. The maximum displacement of the conventional and proposed 18-slot/16-pole machines are about 1.4×10^{-2} mm and 6.1×10^{-3} mm, respectively. Significant vibration will damage the motor structure and simultaneously result in loud acoustic noise. The vibration on stator of the proposed 18-slot/16-pole machine can be effectively limited as expected.

Once the structural response is obtained for the whole

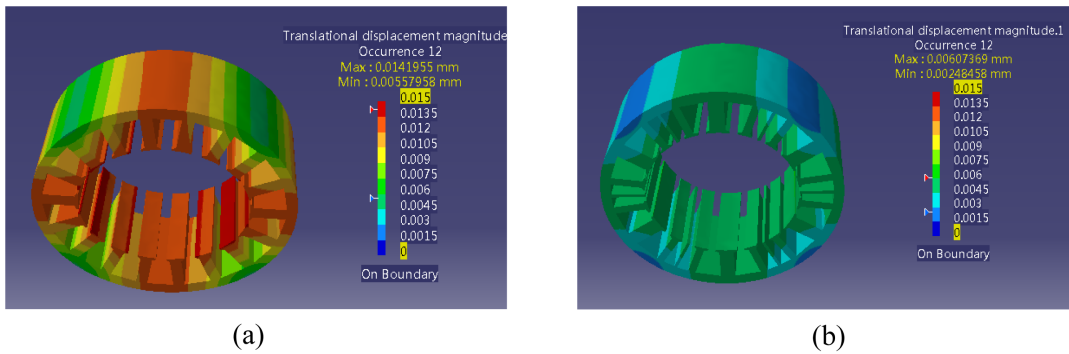

Fig. 12. (Color online) Stator core deformation of 18-slot/16-pole machines. (a) Conventional one. (b) Proposed one.

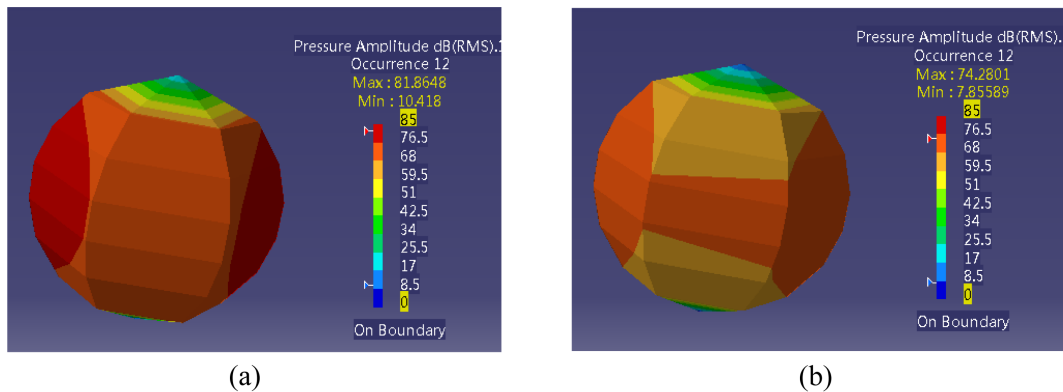

Fig. 13. (Color online) Acoustic noise image at 1200 Hz of 18-slot/16-pole machines. (a) Conventional one. (b) Proposed one.

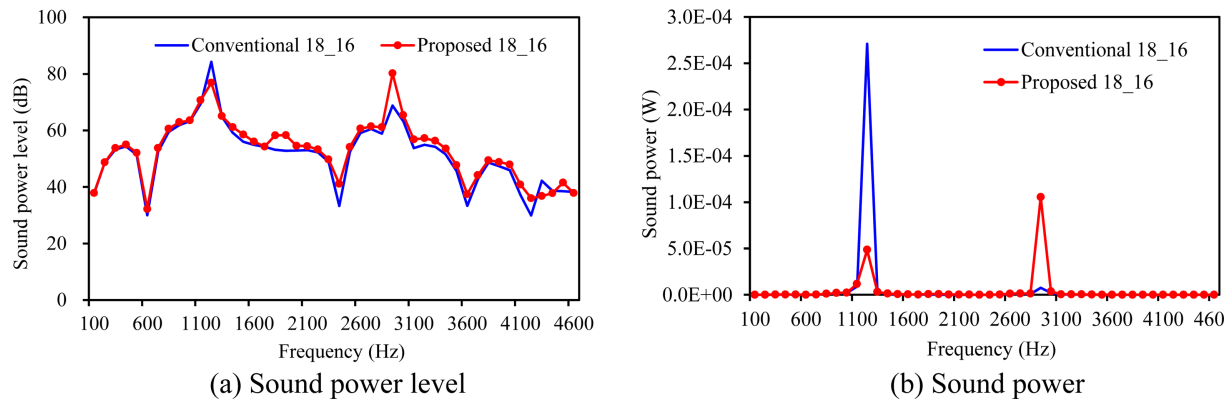

Fig. 14. (Color online) Sound power levels of load configuration in range [100 Hz; 5600 Hz].

frequency range of interest, the structural response can be used as the boundary condition for acoustic model to calculate acoustic noise. In this work, vibration and noise is carried out to perform this task to generate acoustic noise. As shown in Fig. 13(a), the acoustic pressure of the conventional 18-slot/16-pole machine on circular surface of the measurement field is around 81 dB at 1200 Hz. However, the acoustic pressure of the proposed 18-slot/16-pole machine is around 74 dB at the same frequency as shown in Fig. 13(b). So, the proposed 18-slot/16-pole machine can effectively minimize sound pressure amplitude.

Sound power levels of both machines are compared in Fig. 14 in the range [100 Hz; 5600 Hz]. It is noted that the proposed machine can significantly reduce the acoustic noise at 1200 Hz and 4300 Hz. When this new stator structure is adopted, the total acoustic power of conventional motor varies from 84.33 dB to 76.86 dB. It can be seen that high frequency sound power is increased but the total sound power is decreased. The corresponding sound power can be calculated from (14)

$$L_w = 10 \lg \frac{W}{W_0} \quad (14)$$

where L_w is the sound power level, W is the sound power and the value of W_0 is 10^{-12} . Figure 14(b) shows the corresponding sound power of both machines. It is noted that the sound power is decreased about 84% in the proposed machine. Therefore, the machine vibration and noise will be weakened with decrease of tooth harmonic components.

4. Conclusion

In this paper, a new method has been proposed to reduce windings tooth harmonics in FSCW-PM machines. Meanwhile, a stator structure has been obtained and

designed on the method of reducing tooth harmonic. Moreover, the 12-slot/10-pole and 18-slot/16-pole machines have been investigated to verify this new method. Good agreement is obtained between theory and simulation. In addition, the FEM results confirm that the reduced tooth harmonic can decrease the EC loss and further decrease the machine operation temperature with no sacrifice of torque. Furthermore, the tooth harmonic component reduction in the windings MMF can decrease the unbalanced magnetic force. As a result, the vibration and noise of the proposed machine can be effectively weakened.

Acknowledgments

This work was supported by the National Natural Science Foundation of China (Projects 51477068 and 51422702), by the Six Talent Peaks Project of Jiangsu Province (Project 2017-KTHY-011), and by the Priority Academic Program Development of Jiangsu Higher Education Institutions.

References

- [1] Z. Q. Zhu and Y. Liu, *IEEE Trans. Ind. Electron.* **65**, 5 (2018).
- [2] Y. Jiang, Z. Zhang, W. Jiang, and J. Huang, *IET Electr. Power Appl.* **12**, 4 (2018).
- [3] R. Z. Haddad, C. A. Lopez, and S. N. Foster, *IEEE Trans. Ind. Appl.* **53**, 6 (2017).
- [4] Y. Yokoi, T. Higuchi, and Y. Miyamoto, *IET Electr. Power Appl.* **10**, 4 (2016).
- [5] N. Tang and I. P. Bron, *IEEE Trans. Magn.* **54**, 5 (2018).
- [6] Y. Yao and Q. Lu, *IEEE Trans. Magn.* **53**, 11 (2017).
- [7] Y. Li, D. Bobba, E. Schubert, and H. Ding, *IEEE Trans. Transport. Electrification*, **3**, 1 (2017).
- [8] W. Kong, M. Kang, and D. Li, *IEEE Trans. Power Electron* **33**, 7 (2018).

- [9] Y. Yokoi, T. Higuchi, and Y. Miyamoto, *IET Electr. Power Appl.* **10**, 4 (2016).
- [10] G. Dajaku, W. Xie, and D. Gerling, *IEEE Trans. Magn.* **50**, 5 (2014).
- [11] S. S. Nair, J. Wang, R. Chin, L. Chen, and T. Sun, *IEEE Trans. Energy Convers.* **32**, 2 (2017).
- [12] C. Lee, H. Seol, S. Lee, and D. Kang, *IEEE Trans. Magn.* **53**, 11 (2017).
- [13] N. Bianchi, S. Bolognani, and E. Fornasiero, *IEEE Trans. Ind. Appl.* **46**, 6 (2010).
- [14] E. Ghosh, A. Mollaeian, S. Kim, J. Tjong, and N. C. Kar, *IEEE Trans. Magn.* **53**, 11 (2017).
- [15] B. Tong, Y. Qingxin, Y. Rongge, and Z. Lihua, *IEEE Trans. Magn.* **53**, 6 (2017).
- [16] G. Dajaku and D. Gerling, *IEEE Trans. Magn.* **49**, 6 (2013).
- [17] Y. Xu, Q. Yuan, J. Zou, Y. Yao, and G. Zhu, *IET Electr. Power Appl.* **7**, 3 (2013).
- [18] H. Jingzhu and L. Dichen, *IET Electr. Power Appl.* **10**, 4 (2016).
- [19] F. Lin, S. Zuo, and X. Wu, *IET Electr. Power Appl.* **10**, 9 (2016).
- [20] R. Z. Haddad, C. A. Lopez, S. N. Foster, and E. G. Strangas, *IEEE Trans. Ind. Appl.* **53**, 6 (2017).
- [21] H. Kim, D. Kim, and J. Hong, *IEEE Trans. Magn.* **50**, 2 (2014).
- [22] X. Chen, J. Wang, and V. I. Patel, *IEEE Trans. Magn.* **50**, 11 (2014).
- [23] M. I. Masoud, A. Saleem, and R. A. Abri, *IET Electr. Power Appl.* **11**, 4 (2018).
- [24] L. Zhang, Y. Fan, and R. D. Lorenz, *IEEE Trans. Ind. Veh. Technol.* **67**, 2 (2018).
- [25] A. S. Abdel-Khalik, S. Ahmed, and A. M. Massoud, *IEEE Trans. Magn.* **51**, 5 (2015).