

## Effect of Bias Magnetic Field on Magnetolectric Characteristics in Magnetostrictive/Piezoelectric Laminate Composites

Lei Chen<sup>1\*</sup> and Yulin Luo<sup>2</sup>

<sup>1</sup>Key Lab of Computer Vision and Intelligent Information System, Chongqing University of Arts and Sciences, Chongqing 402160, China

College of Optoelectronic Engineering, Chongqing University, Chongqing City, 400044, P.R. China

<sup>2</sup>Engineering school, Cardiff University, Cardiff City, CF102FF, UK

(Received 28 June 2015, Received in final form 24 August 2015, Accepted 16 September 2015)

The magnetolectric (ME) characteristics for Terfenol-D/PZT laminate composite dependence on bias magnetic field is investigated. At low frequency, ME response is determined by the piezomagnetic coefficient  $d_{33,m}$  and the elastic compliance  $s_{33}^H$  of magnetostrictive material,  $d_{33,m}$  and  $s_{33}^H$  for Terfenol-D are inherently nonlinear and dependent on  $H_{dc}$ , leading to the influence of  $H_{dc}$  on low-frequency ME voltage coefficient. At resonance, the mechanical quality factor  $Q_m$  dependences on  $H_{dc}$  results in the differences between the low-frequency and resonant ME voltage coefficient with  $H_{dc}$ . In terms of  $\Delta E$  effect, the resonant frequency shift is derived with respect to the bias magnetic field. Considering the nonlinear effect of magnetostrictive material and  $Q_m$  dependence on  $H_{dc}$ , it predicts the low-frequency and resonant ME voltage coefficients as a function of the dc bias magnetic field. A good agreement between the theoretical results and experimental data is obtained and it is found that ME characteristics dependence on  $H_{dc}$  are mainly influenced by the nonlinear effect of magnetostrictive material.

**Keywords :** composite materials, mechanical quality factor, bias magnetic field, Magnetolectric (ME)

### 1. Introduction

The magnetolectric (ME) effect is defined as the electric polarization of ME composite material upon application of a magnetic field or inversely the magnetization of ME composite material upon application of an electric field [1]. The ME effect provides a transduction method between magnetic and electric field signals. Consequently, ME composite materials can be used as transducers in wireless powering systems, energy harvesting and magnetic field sensors, with the main advantage being that they require no external power to operate. Especially, the ME laminate composite has a relative higher ME voltage coefficient and a simpler fabricating procedure, which has attracted wide concern [2-10].

The ME response of ME laminate composite is influenced by many factors, and the traditional ME theories only pay attentions to the relationship between ME

voltage coefficient ( $\alpha_{ME} = dV/dH$ , where  $V$  and  $H$  are the induced voltage and applied magnetic field, respectively) and the material parameters as well as thickness ratio [3, 4]. In recent years most experimental results have confirmed that ME characteristics in magnetostrictive/piezoelectric laminate composites are intensively dependent on the dc bias magnetic field  $H_{dc}$ , because magnetostrictive material exhibits nonlinear behaviors. The traditional ME theories on the basis of the linear constitutive relationships of magnetostrictive material is inappropriate to describe the nonlinear ME response in a broad range of the bias magnetic field. Therefore, some theoretical researches about the influence of bias magnetic field on ME response are reported [5-9]. Liu *et al.* tried to explain the problem by numerical and finite element methods, but it's still not enough to reveal the inherence of the dependence [6]. Nan *et al.* predicted the dependence of ME response on  $H_{dc}$  by using the Green's function technique and taking into consideration the nonlinear dependence of the magnetostriction of Terfenol-D on  $H_{dc}$ , but the model is not in an explicit form [5, 8]. Zhou *et al.* proposed a numerical model of ME conversion characteristics for

©The Korean Magnetism Society. All rights reserved.

\*Corresponding author: Tel: +86-23-49891553

Fax: +86-23-49891553, e-mail: 67638515@163.com

ME composites based on a nonlinear magnetostrictive constitutive relation, but it is obviously inconvenient for practical applications due to adopting five fitting parameters to fit the experimental results [7]. Besides that, significant increase in the ME voltage coefficient is observed at resonance due to the strain by a factor called the mechanical quality factor  $Q_m$  of the composites, but the research on the connection of bias magnetic field and  $Q_m$  is rare [11].

Considering these situations, we research the dependence of ME characteristics for Terfenol-D/PZT laminate composite on  $H_{dc}$ . It further analyzes the ME effect for the magnetic-mechanical-electric multi-field coupling effect with a theoretical model based on the nonlinear constitutive relationships of magnetostrictive material, motion equation for the composite plate, and ME equivalent circuit method. In this theoretical model, the interface coupling parameter and the  $H_{dc}$  dependence of  $Q_m$  are taken into consideration. Because piezomagnetic coefficient  $d_{33,m}$  and the elastic compliance  $s_{33}^H$  of magnetostrictive material is vital to the ME response,  $d_{33,m}$  and  $s_{33}^H$  for Terfenol-D are inherently nonlinear and dependent on  $H_{dc}$ , leading to the influence of  $H_{dc}$  on low-frequency ME voltage coefficient. It indicates that the optimization  $H_{dc}$  at low frequency can be determined by the piezomagnetic coefficient and the elastic compliance curves of Terfenol-D. Additionally,  $Q_m$  exhibits very sensitive dependences on  $H_{dc}$ , which results in the differences between the low-frequency and resonant ME voltage coefficient with  $H_{dc}$ . The resonant frequency shift is derived with respect to the bias magnetic field due to changes in Young's modulus. This study plays a guiding role in the ME composites design for real applications.

## 2. Experiment

We fabricated the Terfenol-D/PZT-8 bi-layered laminate composites, as shown in Fig. 1. The magnetostrictive (M) layer Terfenol-D is grain-oriented in the length direction with the dimension of 12 mm × 6 mm × 1 mm, and the piezoelectric (P) layer PZT is polarized in thickness direction with dimension of 12 mm × 6 mm × 0.8 mm.

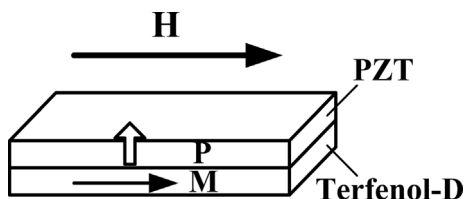

Fig. 1. The schematics of the Terfenol-D/PZT-8 bi-layered laminate composites.

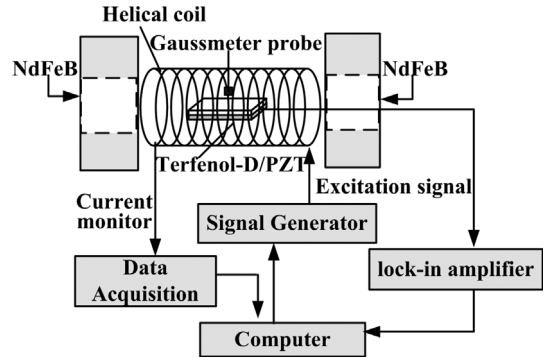

Fig. 2. The experimental setup for the ME characterization.

The Terfenol-D and PZT plates are dipped in organic impregnant to clean at first. After that, the sample is prepared by stacking and then bonding the two plates with conductive sliver epoxy and cured at 100°C 4 hours for good mechanical coupling.

In our experiments, a helix coil with a turn number of 245, a length of 67 mm and a diameter of 41 mm produces a small ac magnetic field ( $H_{ac}$ ) with peak-peak value 1 Oe. A signal generator (Tektronix AFG3021B) monitoring by the computer (Labview VI program) generates a controllable excitation current to the helix coil. A pair of NbFeB magnets (commercial brand N50) is located at the two sides of the ME laminate composites along the longitudinal axis, which is used to generate dc bias magnetic field ( $H_{dc}$ ). The magnitude of  $H_{dc}$  is adjusted by varying the distance between NdFeB magnets and measured with a Gauss meter, which ranges from 0 Oe to 700 Oe. The ME composites are placed at the center of the cylindrical shell. Both the  $H_{ac}$  and  $H_{dc}$  are parallel to the longitudinal direction of the sample. The induced ME voltage across the two electrodes of the piezoelectric material PZT are transferred to a lock-in amplifier (Stanford, SR830), and are then acquired by the data acquisition card (National Instruments Model PCI-6115). The acquired data are stored in the computer with Labview VI program. And the corresponding experimental setup is illustrated in Fig. 2.

## 3. Results and Discussion

Figure 3 shows the low-frequency ME voltage coefficient  $\alpha_{ME}^{low}$  for the Terfenol-D/PZT bi-layered composites at ac driving magnetic field  $H_{ac} = 1$  Oe under the frequency of 1 kHz as a function of dc bias magnetic field ( $H_{dc}$ ). From Fig. 3, it can be seen that the ME voltage coefficient strongly depends on  $H_{dc}$ , which increases from approximately zero at  $H_{dc} = 0$  Oe to a maximum value 14.63 mV/Oe at an optimum bias magnetic field of 510

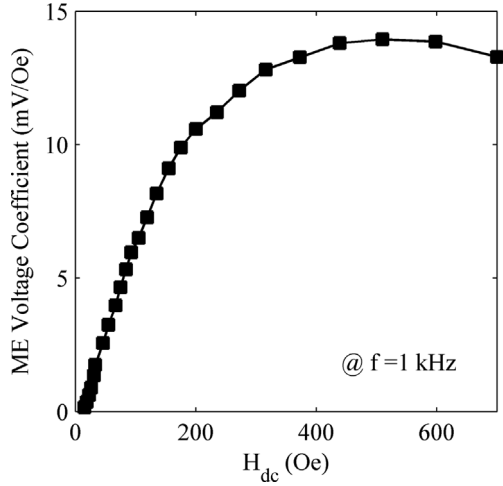

**Fig. 3.** The low-frequency ME voltage coefficient for the Terfenol-D/PZT laminated composite as a function of  $H_{dc}$ .

Oe, then gradually decreases as  $H_{dc}$  increases further. The  $H_{dc}$  dependence of the ME voltage coefficient results from the  $H_{dc}$  dependence of piezomagnetic coefficient  $d_{33,m}$  and the elastic compliance  $s_{33}^H$  of Terfenol-D.

According to the magneto-elasto-electric equivalent circuit method, the ME voltage coefficient for ME laminate composite at low frequency can be determined by equation (1), as [4]

$$\alpha_{ME}^{low} = \beta \frac{n(1-n)td_{33,m}d_{31,p}}{\epsilon_{33}[n(1-k_{31}^2)s_{11}^E + (1-n)s_{33}^H]}, \quad (1)$$

where  $d_{31,p}$  is piezoelectric coefficient,  $\epsilon_{33}$  is the permittivity tensor,  $t$  is the thickness of ME composite,  $n$  is the thickness ratio of magnetostrictive layers in ME composite,  $\beta$  is the interface coupling parameter,  $k_{31}$  and  $s_{11}^E$  is the electromechanical coupling coefficient and the elastic compliance of piezoelectric material, respectively.

In Eq. (1), ME voltage coefficient is related to the piezomagnetic coefficient  $d_{33,m}$  and the elastic compliance  $s_{33}^H$  of Terfenol-D. However,  $d_{33,m}$  and  $s_{33}^H$  of Terfenol-D are not a constant. Many experiments have reported that the magneto-mechanical response of Terfenol-D is nonlinear and coupled [12-15]. It leads to the  $d_{33,m}$  and  $s_{33}^H$  change with the bias magnetic field. According to Zheng's theory [12], when the pre-stress exerted on a Terfenol-D is zero, the relational expression between piezomagnetic coefficient  $d_{33,m}$  and  $H_{dc}$  is derived as

$$d_{33,m} = 2\lambda_s \left( \coth(\eta H_{dc}) - \frac{1}{\eta H_{dc}} \right) \times \left( \eta(1 - \coth(\eta H_{dc})^2) + \frac{1}{\eta H_{dc}^2} \right), \quad (2)$$

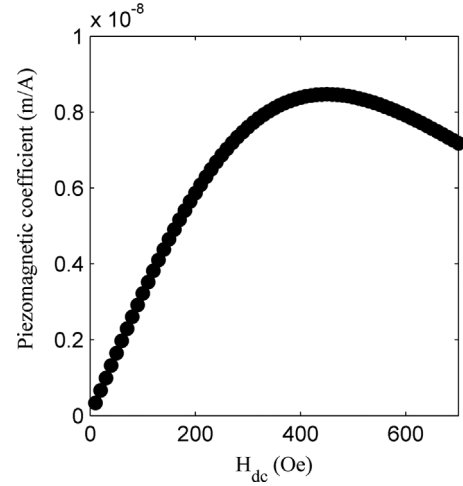

**Fig. 4.** Calculated piezomagnetic coefficient as a function of the dc bias magnetic field.

where  $\lambda_s$  is the saturation magnetostrictive coefficient,  $\eta = 3\chi_m/M_s$ ,  $\chi_m$  and  $M_s$  are the magnetic susceptibility and the saturated magnetization, respectively. Figure 4. shows the calculated piezomagnetic coefficient on  $H_{dc}$ .

The elastic compliance of Terfenol-D at constant magnetic field  $H_{dc}$  can be calculated as

$$s_{33}^H = \frac{1}{E} = \frac{\partial \epsilon}{\partial \sigma} \Big|_{H_{dc}=const} = \frac{1}{E_{m0}} - \frac{E_{ms} - E_{m0}}{E_{m0}E_{ms}} \left( \coth(\eta H_{dc}) - \frac{1}{\eta H_{dc}} \right)^2, \quad (3)$$

where  $E_{m0}$  and  $E_{ms}$  are the initial and saturation Young's modules of Terfenol-D, respectively. The reciprocal of the elastic compliance is the Young's module, and one

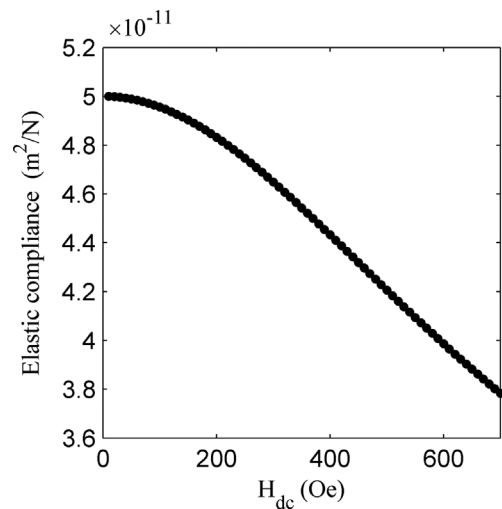

**Fig. 5.** Calculated elastic compliance as a function of the dc bias magnetic field.

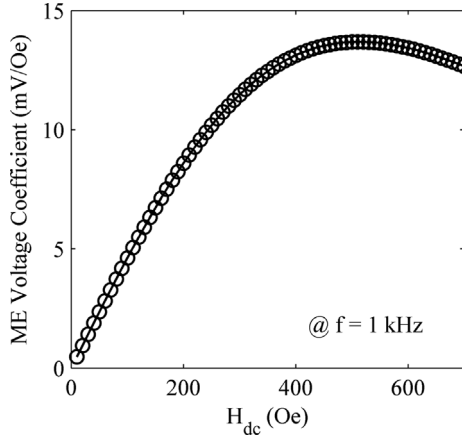

**Fig. 6.** Calculated low-frequency ME voltage coefficient as a function of the dc bias magnetic field.

famous properties of Terfenol-D is its giant  $\Delta E$  effect, i.e., the Young's module of Terfenol-D varies with the change of  $H_{dc}$  [13, 14]. Correspondingly, the elastic compliance change in accordance with the change of dc bias magnetic field (as shown in Fig. 5).

The magnetostrictive material Terfenol-D parameters are  $E_{m0} = 20$  Gpa,  $E_{ms} = 60$  Gpa,  $\chi_m = 20$ ,  $\lambda_s = 0.001$ ,  $\mu_0 M_s = 1.6$  T,  $\rho_m = 9200$  kg/m<sup>3</sup>. The piezoelectric material PZT parameters are  $d_{31,p} = 93$  pC/N,  $\epsilon_{33} = 1000$ ,  $\rho_m = 7600$  kg/m<sup>3</sup>,  $k_{31} = 0.38$ ,  $s_{11}^E = 11.1 \times 10^{-12}$  m<sup>2</sup>/N. The calculated low-frequency ME voltage coefficient on  $H_{dc}$  can be plotted as Fig. 6. As seen from the comparison, the experimental result and theoretical value have a good agreement qualitatively and quantitatively in Fig. 3 and Fig. 6. Clearly, because piezomagnetic coefficient and elastic compliance is vital to the ME response, the magneto-mechanical coupling for Terfenol-D is inherently nonlinear and dependent on  $H_{dc}$ , leading to the influence of  $H_{dc}$  on low-frequency ME voltage coefficient.

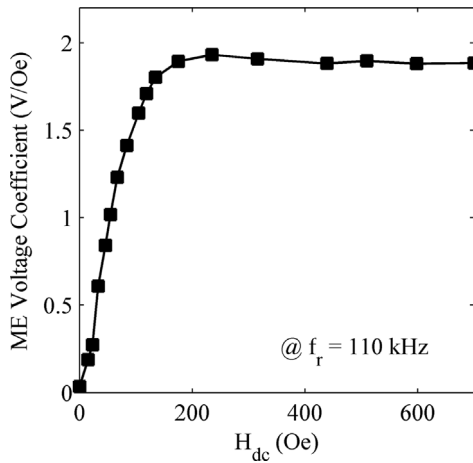

**Fig. 7.** The resonance ME voltage coefficients for the Terfenol-D/PZT laminated composite as a function of  $H_{dc}$ .

The resonance ME voltage coefficients for Terfenol-D/PZT composite at different bias magnetic fields are measured, as illustrated in Fig. 7. When bias magnetic field  $H_{dc}$  is above 175 Oe, the resonance ME voltage coefficient is within the range of 1.88-1.9 V/Oe, and once  $H_{dc}$  is below 135 Oe, the coefficient decreases rapidly. In comparison, there are some differences between the varying trend of the low-frequency and resonant ME voltage coefficient with  $H_{dc}$ . This is principally because effective mechanical quality factor of ME composite  $Q_m$  exhibits very sensitive dependences on  $H_{dc}$ . The  $Q_m$  directly influences the magneto-elastic-electric coupling effect in the ME composite and the magneto-elastic damping in the magnetostrictive layers, leading to a strong influence on the resonant ME effect.

Based on the magneto-elasto-electric equivalent circuit method, the ME voltage coefficient  $\alpha_{ME}^R$  at resonance can be derived as

$$\begin{aligned} \alpha_{ME}^R &= \frac{8Q_m}{\pi^2} \beta \frac{n(1-n)td_{33,m}d_{31,p}}{\epsilon_{33}[n(1-k_{31}^2)s_{11}^E + (1-n)s_{33}^H]} \approx \frac{8Q_m}{\pi^2} \alpha_{ME}^{low} \\ &\approx \frac{4Q_m}{\pi^2} \lambda_s \beta \frac{n(1-n)td_{31,p}}{\epsilon_{33} \left[ \frac{1}{E_{m0}} - \frac{E_{ms} - E_{m0}}{E_{m0}E_{ms}} \left( \coth(\eta H_{dc}) - \frac{1}{\eta H_{dc}} \right)^2 \right]} \\ &\quad \times \eta (1 - \coth(\eta H_{dc})^2) + \frac{1}{\eta H_{dc}^2} \times \left( \coth(\eta H_{dc}) - \frac{1}{\eta H_{dc}} \right). \end{aligned} \quad (4)$$

In Eq. (4), the resonant ME voltage coefficient is directly proportional to  $Q_m$  and the low ME voltage coefficient.  $Q_m$  is an inverse measure of damping in a material (or system). For the ME composite,  $Q_m^{-1}$  represents mechanical energy dissipation [11]. According to the frequency dependency for the ME voltage coefficient, it estimates the mechanical energy dissipation ( $Q_m^{-1}$ ) for ME composite defined as [12]

$$Q_m^{-1} = \frac{\Delta f_r}{f_r}, \quad (5)$$

where  $f_r$  and  $\Delta f_r$  are the resonant frequency and the 3dB frequency bandwidth respectively.

The mechanical energy dissipation  $Q_m^{-1}$  dependence on  $H_{dc}$  can be obtained as Fig. 8. In the previous theoretical research, it is often inappropriate to set a constant value  $Q_m^{-1}$  to describe the nonlinear resonant ME response in a broad range of the applied dc magnetic field. From Fig. 8, we can see that as  $H_{dc}$  increases,  $Q_m^{-1}$  first increases until it reaches a certain maximum at  $H_{dc} = 439$  Oe and then decreases past that point. This can be understood as a result of the dependence of the mechanical damping for Terfenol-D on  $H_{dc}$ . For the ME composite with PZT and

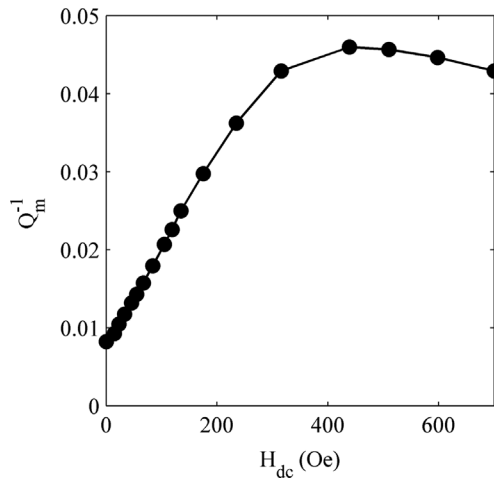

**Fig. 8.** The mechanical energy dissipation  $Q_m^{-1}$  for the Terfenol-D/PZT laminated composite as a function of  $H_{dc}$ .

Terfenol-D,  $Q_m^{-1}$  can be given by [11]

$$Q_m^{-1} = (1 - n)Q_{mech,pzt}^{-1} + nQ_{mech, Terfenol-D}^{-1} + Q_{face}^{-1}, \quad (7)$$

where  $Q_{mech,pzt}^{-1}$  and  $Q_{mech, Terfenol-D}^{-1}$  are the mechanical damping of PZT and Terfenol-D, respectively.  $Q_{face}^{-1}$  is the loss at the interface of PZT and Terfenol-D layers.  $n$  is the volume ratio of the Terfenol-D layer in the ME composite.

From Eq. (6), the mechanical energy dissipation is mainly dominated by the mechanical damping of Terfenol-D and PZT. However, the mechanical damping of Terfenol-D arises from the magnetostrictive stress-strain hysteresis loop which is caused by the irreversible motion of magnetic domains and domain walls. Taking into consideration the fact that the shapes and areas of the stress-strain hysteresis loops dependence on  $H_{dc}$  results in the

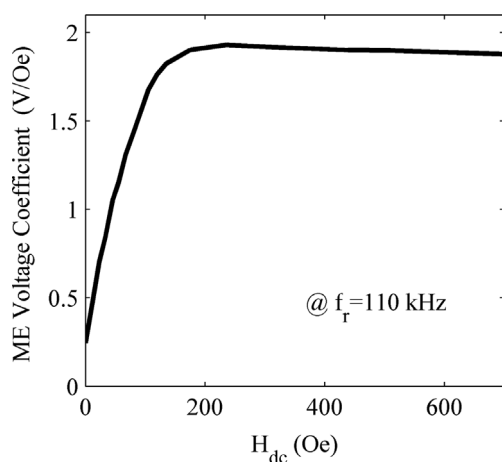

**Fig. 9.** Calculated resonant ME voltage coefficient as a function of  $H_{dc}$ .

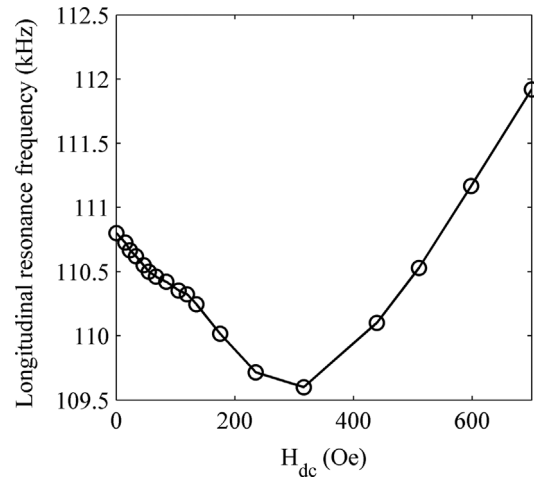

**Fig. 10.** The longitudinal resonant frequency  $f_r$  for the PZT/Terfenol-D laminated composite as a function of  $H_{dc}$ .

mechanical damping of Terfenol-D dependence on  $H_{dc}$ , it is easy to understand that the mechanical energy dissipation ( $Q_m^{-1}$ ) for ME composite strongly depends on  $H_{dc}$ .

Using the above data, we can calculate the dependence of the resonant ME voltage coefficient on  $H_{dc}$  according to the Eq. (5) and the results are shown in Fig. 9. The ME voltage coefficient values calculated by Eq. (5) and the experimental result agree with each other quite well (as shown in Fig. 7 and Fig. 9).

Figure 10 shows the longitudinal resonant frequency ( $f_r$ ) for the PZT/Terfenol-D laminated composite as a function of  $H_{dc}$  from 0 to 700 Oe. The resonant frequency decreases to a minimum value at  $H_{dc} = 316$  Oe, and then increases with  $H_{dc}$ , showing a “V” shape in the range of 0-700 Oe. The resonant frequency shift is derived with respect to the bias magnetic field due to changes in Young’s modulus. As mentioned previously, the Young’s modulus  $E$  for the magnetostrictive material varies with the applied dc magnetic field. The reciprocal of the elastic compliance is the Young’s module. The resonance frequency is influenced by the elastic compliance, geometry dimension and density of laminate composite. Therefore, the  $\Delta E$  effect of Terfenol-D induces the resonant frequency shift phenomenon.

## 4. Conclusions

The significant dependence of dc magnetic bias field on the ME characteristics in Terfenol-D/PZT laminate composite is studied experimentally and theoretically. It has been demonstrated that: 1) The ME voltage coefficient at the low frequency strongly depends on  $H_{dc}$ , which is

mainly determined by the  $d_{33,m}$  and  $s_{33}^H$  curves of Terfenol-D with  $H_{dc}$ ; 2) At the resonant mode,  $Q_m$  exhibits very sensitive dependences on  $H_{dc}$ , which results in the differences between the low-frequency and resonant ME voltage coefficient with  $H_{dc}$ ; 3) The resonant frequency of ME laminate composite shifts with the influence of the  $\Delta E$  effect of Terfenol-D.

### Acknowledgements

This research is supported by the National Natural Science Foundation of China (Grant No. 61304255), and the China Postdoctoral Science Foundation (No. 2013M530393 and No. 2014T70851), and the Chongqing Postdoctoral Science Special Foundation (No. Xm201304), and the Chongqing Research Program of Basic Research and Frontier Technology (No. cstc2015jcyjBX0019).

### References

- [1] M. Fiebig, *J. Phys. D: Appl. Phys.* **38**, R123 (2005).
- [2] J. Ryu, S. Priya, A. V. Carazo, and K. Uchino, *J. Am. Ceram. Soc.* **84**, 2905 (2001).
- [3] K. Prabakar, Josephine Mirunalini, N. Shara Sowmya, J. Arout Chelvane, M. Mahendiran, S. V. Kamat, and A. Srinivas, *Physica B* **448**, 336 (2014).
- [4] S. X. Dong, J. F. Li, and D. Viehland, *IEEE Trans. Ultrason. Ferroelectr. Freq. Control.* **50**, 1253 (2003).
- [5] C. W. Nan, M. Li, and J. H. Huang, *Phys. Rev. B* **63**, 144415 (2001).
- [6] Y. X. Liu, J. G. Wan, J. M. Liu, and C. W. Nan, *J. Appl. Phys.* **94**, 5118 (2003).
- [7] H. M. Zhou, L. M. Xuan, C. Li, and J. Wei, *J. Magn. Magn. Mater.* **323**, 2802 (2011).
- [8] C. W. Nan, M. Li, X. Feng, and S. Yu, *Appl. Phys. Lett.* **78**, 2527 (2001).
- [9] R. Belouadah, D. Guyomar, B. Guiffard, and J. W. Zhang, *Physica B* **406**, 2821 (2011).
- [10] S. Priya, R. Islam, S. Dong, and D. Viehland, *J. Electroceram.* **19**, 147 (2007).
- [11] Y. Yao, Y. Hou, S. Dong, X. Huang, Q. Yu, and X. Li, *J. Alloys Compd.* **509**, 6920 (2011).
- [12] X. J. Zheng and X. E. Liu, *J. Appl. Phys.* **97**, 053901 (2005).
- [13] M. B. Moffet, A. E. Clark, M. Wun-Fogle, J. Linberg, J. P. Teter, and E. A. McLaughlin, *J. Acoust. Soc. Am.* **89**, 1448 (1991).
- [14] K. B. Hathaway and A. E. Clark, *MRS Bull.* **18**, 34 (1993).
- [15] M. E. H. Benbouzid, G. Reyne, and G. Meunier, *IEEE Trans. Magn.* **31**, 1821 (1995).