

Treatment^{WD} Pulse Application for Transcranial Magnetic Stimulation

Dong-Ho Ha¹, Jun-Il Kim², Sun-Min Lee³, Gak Hwang Bo⁴, Whi-Young Kim¹, and Sun-Seob Choi^{1*}

¹Department of Radiology/Neuro radiology Section, Dong-A University Medical Center, Busan 602-715, Korea

²Department of Nursing, Gaya University, Kyung Nam 621-748, Korea

³Department of Occupational Therapy, Dong-ju College University, Busan 602-715, Korea

⁴Department of Physical Therapy, Daegu University, Kyung Buk 712-714, Korea

(Received 5 November 2011, Received in final form 10 February 2012, Accepted 13 February 2012)

The transcranial magnetic stimulation recharges the energy storing condenser, and sends the stored energy in the condenser to the pulse shaping circuit, which then delivers it to the stimulating coil. The previous types of transcranial magnetic stimulation required a booster transformer, secondary rectifier for high voltages and a condenser for smooth type. The energy storing condenser is recharged by switching the high-voltage direct current power. Loss occurs due to the resistance in the recharging circuit, and the single-pulse output energy in the transcranial magnetic stimulation can be changed because the recharging voltage cannot be adjusted. In this study a booster transformer, which decreases the volume and weight, was not used. Instead, a current resonance inverter was applied to cut down the switching loss. A transcranial magnetic stimulation, which can simultaneously alter the recharging voltage and pulse repeats, was used to examine the output characteristics.

Keywords : WD (Wide-Depth), treatment, transcranial, magnetic, stimulation

1. Introduction

To induce neural stimulation using the transcranial magnetic stimulation, a time varying magnetic field of 1-2 Tesla generally needs to be generated in pulse form for hundreds of μs [1, 2]. To generate a continuous muscular contraction, the time varying magnetic field frequency needs to be 1-60 Hz. To achieve a discharging current > 1000 A with a voltage > 1000 V in the capacitor for storing the energy required by the transcranial magnetic stimulation, a LC resonance circuit comprised of a stimulating coil that forms a strong time varying magnetic field by discharging it were used. The transcranial magnetic stimulation needs to exert the energy that is stored in the capacitor in short but strong high voltages and high electric currents to form the time varying magnetic field of a certain amount of Tesla. To reduce the power lost in the circuit where discharging occurs, the energy exerted in the coil is collected by a capacitor, and the voltage of the discharging capacitor is reversed when this occurs. An excessive electric current is generated in the circuit when an excessive electric current flows into

the recharging power, which destroys the power output or increases the power current [3-5]. When the voltage of the capacitor is 0 V, the power circuit and capacitor are temporarily turned off. In the transcranial magnetic stimulation, the switching type of power circuit, which uses more than 2 kV that is recharged in the capacitor, greatly decreases the power-factor of the magnetic stimulator by generating a phase-shift and harmonic distortion in the electric current by the inductor and capacitor for the magnetic stimulation [6, 7]. For the transcranial magnetic stimulation to resolve the comprehensive problem, the energy storing condenser is recharged, and the energy stored in the condenser passes through a pulse shaping circuit to trigger the power device and deliver it to the stimulating coil [8, 9] The existing transcranial magnetic stimulation requires a booster transformer, a rectifier and smooth rectifier, and a condenser for the secondary-side high voltage [10]. The condenser for storing energy is recharged by switching the high-voltage direct current power. Loss is generated by the resistance in the recharging route, and a single pulse output energy cannot be changed because the recharged power cannot be adjusted [10].

This study employed a smaller version with decreased volume and weight because a booster transformer was not

*Corresponding author: Tel: +82-51-200-3449

Fax: +82-51-200-3235, e-mail: neurondyag@gmail.com

used, and the switching loss was decreased by applying current resonance inverter. The transcranial magnetic stimulation was used to examine the output characteristics.

2. Design

To stimulate a nerve with magnetic pulse, the size of the electric field induced by the time varying magnetic field needs to reach the stimulating level. The device needs to be able to induce an electric field more than tens of V/m in the neural area. To induce this electric field, a magnetic field of 1-2 Tesla needs to be switched within 200 μsec , from the stimulating coil and epidermis to the nerve.

To generate such a magnetic field, a stimulating coil with a diameter of 0.6 cm, tens of wires with thousands of amps need to flow instantly. As a method to instantly allow a large electric current to the stimulating coil, the stimulating coil is temporarily discharged by recharging the capacitor. When an electric current flows in the coil wire, a magnetic field is formed around the coil wire based on Fleming's right hand rule, and an electric field is induced perpendicular to the direction of the magnetic field generated. An eddy current is generated inside the conductor when the time varying magnetic field forms around an electric conductor, such as a metal. The electrical conductance of the human body is approximately 0.4 m, which is quite low compared to high-quality conductors such as a metal but it has conducting property. An eddy current can be induced inside the human body just like a general electric conductor when a time-varying

magnetic field forms around the human body. The eddy current induced by the time-varying magnetic field employs electrodes inside the human body and has a similar effect to that of inserting the electric current directly. Fig. 1 shows the small sized device. A resonance current type of inverter was applied to decrease the losses caused by switching, and the transcranial magnetic stimulation, which can alter the recharging voltage and pulse repetition rate of the energy storing condenser, was examined. The device consists of a discharge bank and stimulating coil. With this device, the deep and wide application of a stimulating pulse on the human body is possible. The stimulating coil employed copper pipes, 8.5 mm in internal diameter and 10.5 mm in external diameter. A glass fiber coat with a 1,550 V withstand voltage and a 0.25 mm thickness (t) was used primarily for the copper pipes to prevent interference with the cables and other obstacles. For complete shielding, a 5,500 V withstand voltage and 0.25 mm thickness (t) was used. The entire length of the stimulating coil was approximately 4.0 m. The first part was pressed to 13 cm, the latter part to 70 cm, and the final 7 cm was double pressed. The material was heat treated (annealing) for durability and for multi-purpose: overall heating < 660°C for 15 minutes, and 8 minutes for the latter part. The first and second pressing was performed with a 5.45 cm and 6.5 cm thick panel, respectively. The large coil probe was manufactured with a helix type using Litz wire (number of leading wires: 285). The total number of turns was 12 and the diameter was 155 mm. The inductance of this coil was approximately 9.5 μH , and the maximum magnetic field was 1.25 Tesla. The stimulating coil was designed

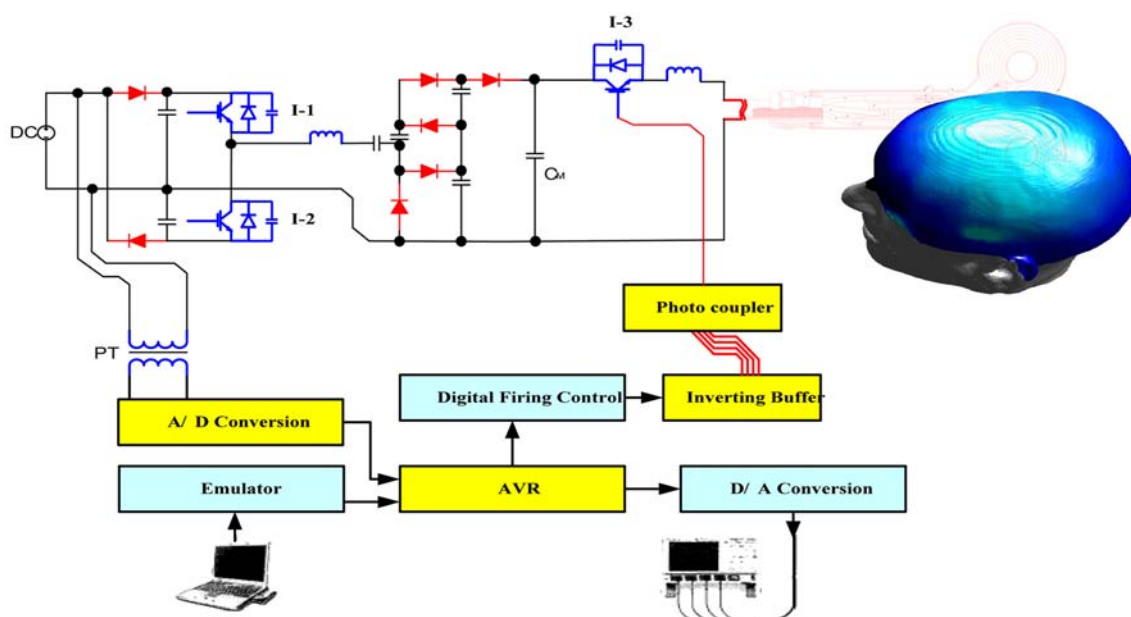

Fig. 1. (Color online) Small sized transcranial magnetic stimulation with decreased volume and weight.

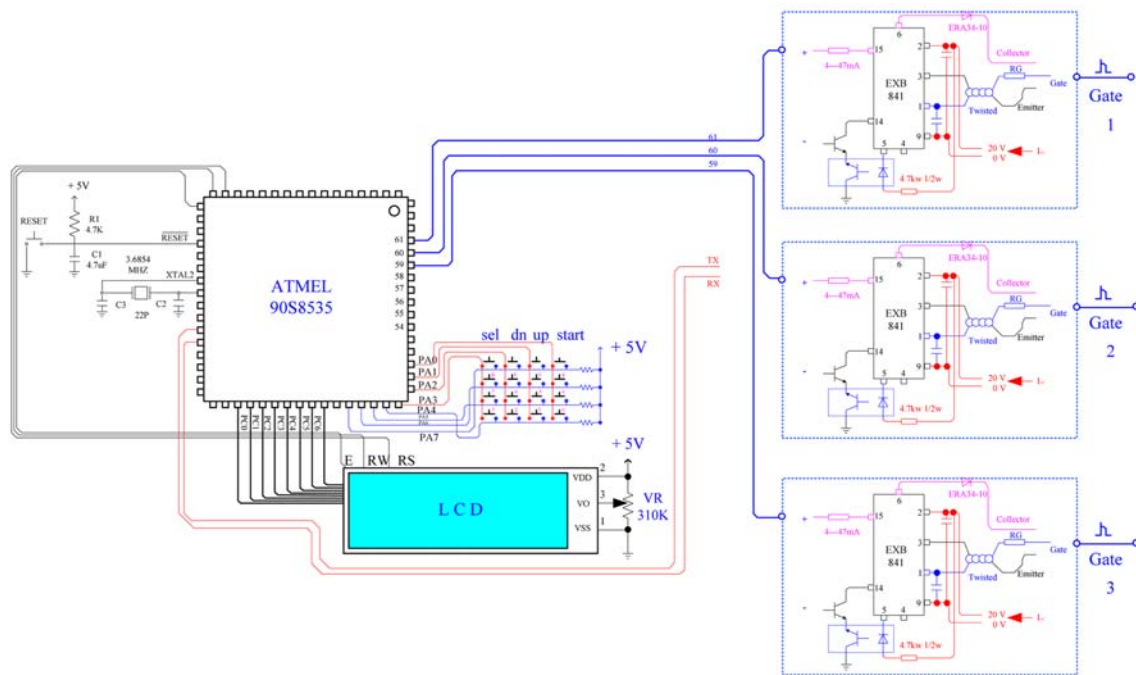

Fig. 2. (Color online) AVR one chip microprocessor to control and operate the energy storing condenser recharging method that employs a resonance current type half wave bridge inverter and Cockcroft-Walton circuit.

and manufactured to treat wide areas, such as the back, shoulders, lower back and abdomen. The small stimulating coil was manufactured with a helix type using Litz wire (number of leading wire : 170). The total number of turns was 10.4, and the diameter was 105 mm. The inductance of this coil was approximately $9.5 \mu\text{H}$, and the maximum magnetic field was 2.25 Tesla. The stimulating coil was designed and manufactured to treat children or narrow areas, such as the neck, elbow, and ankle.

A figure-of-eight coil probe was manufactured with the helix type, connecting the two wires in a figure of ‘8’ manner using Litz wire (number of leading wire : 155). The total number of turns was 10.5, and the diameter was 85 mm. The inductance of this coil was approximately $9.5 \mu\text{H}$, and the maximum magnetic field was 1.26 Tesla. The stimulating coil was designed and manufactured for intensively treating a specific area or the head. In particular, the magnetic field intensity, frequency, train time, pause time and treatment time need to be adjusted. Accordingly, these factors should be considered when designing a transcranial magnetic stimulation. Fig. 2 consists of an AVR one chip microprocessor to control and operate the energy storing condenser recharging method that employs a resonance current type half bridge inverter and a Cockcroft-Walton circuit. The power unit is composed of a main circuit, recharging unit, and trigger circuit. The discharge state is maintained as soon as the stimulating coil is triggered by the trigger circuit. This makes discharging

easier by decreasing the firing potential voltage, lengthening the life of the stimulating coil, and improving the efficiency. The main circuit is composed of a rectifier, resonance current type half bridge inverter, Cockcroft circuit and pulse shaping circuit. The direct current power that has been rectified by the rectifier begins to resonate by switching S_1 and S_2 in order, simultaneously rectify and boost via the Cockcroft circuit, and recharge the condenser. When the recharging to the desired voltage is completed, switch S_M , then triggers the energy in the condenser by transferring it to the stimulating coil via the pulse shaping circuit. For the control unit, the AVR one-

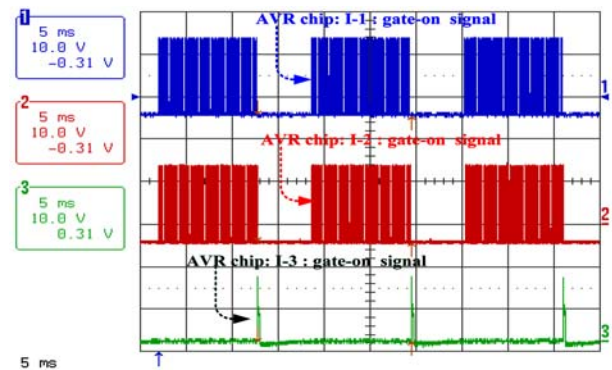

Fig. 3. (Color online) Program that generates a display signal by the AVR receiving the keyboard input from the control circuit. The AVR then generates a timing signal from this, which is displayed on the AVR.

chip micro processor is used to generate the control signal for the S_M operating the half bridge S_1 , S_2 control signal and stimulating coil by a keyboard input. Fig. 3 shows the program that generates the display signal by the AVR receiving the keyboard input from the control circuit, and the AVR generates the timing signal from this, which is displayed on the AVR.

3. Experiment Results

Fig. 4 presents different sizes of current wave forms that come out from the secondary part of the transformer, which generates the control signals from the AVR. The S_M signal is generated with a time interval of 16.69 ms, which shows that the transcranial magnetic stimulation is operating at 60 Hz. Fig. 5 presents the recharging waveform of the resonance current and the operating waveform of the half bridge IGBT S_1 and S_2 , which is generated by the control signal from the AVR. The waveforms a and b are the operating signals for S_1 and S_2 , respectively, and the waveforms c and d present the expanded operating waveforms. The operating signal of the half wave bridge

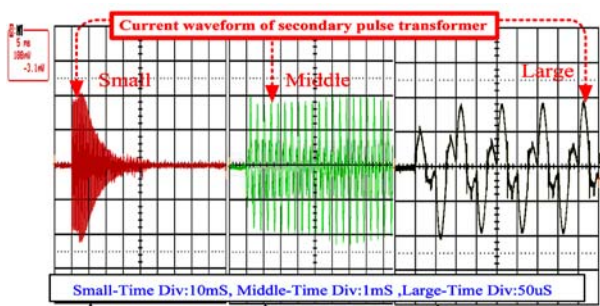

Fig. 4. (Color online) Different sizes of current wave forms that come out from the secondary part of the transformer, which generates the control signals from the AVR.

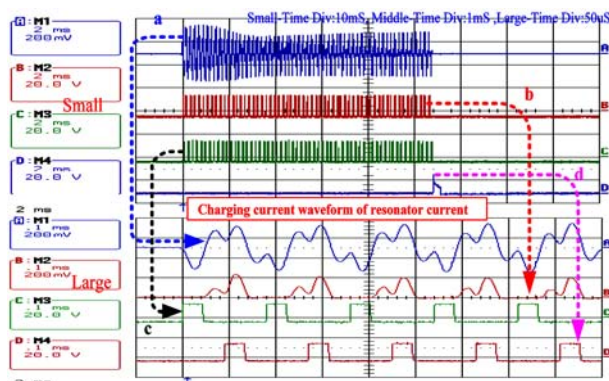

Fig. 5. (Color online) Recharging waveform of the resonance current and operating waveform of the half bridge IGBT I-1, I-2, which is generated by the control signal from the AVR.

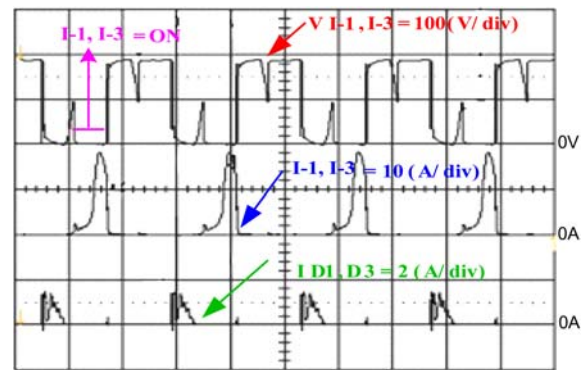

Fig. 6. (Color online) Experimental waveforms for the collector-to-emitter voltage, current of S_1 with their current and bypass current flowing through diode D_3 .

IGBT is generated from two of EXB841 (Fuji Co.), which receives the control signal from the AVR, and the operating signal of SCR amplifies the control signals of the AVR in the amplifying circuit.

This is the operating signal of the SCR and half wave bridge IGBT, as well as the inverter output current waveform that flows through L_R . Fig. 6 shows the experimental waveforms for the collector-to-emitter voltage, and the current of S_1 with their current and bypass current flowing through diode D_3 . The peak value of the inverter output current increases slightly in the initial stages but it stabilizes as the inverter is recharged. The peak inverter current that flows through the reflux diode, which is arranged in a row parallel to the IGBT, decreases gradually because C_M is being recharged gradually. When the stimulating coil waveform shown in Fig. 7 triggers 4 steps simultaneously, the first current waveform is presented, and then the second waveform is then presented with a time delay. The pictures shown below present the measured waveforms magnified at different times. The operating signals of I-1 and I-2 were turned on and off in order according to the time of the resonance current so that the operator is aware of the inverter output current that is being resonant.

Fig. 8 shows the recharging voltage based on the switching time, its recharging energy and the output energy of single pulse transcranial magnetic stimulation. The recharging voltage sharply increases in the beginning but it slows down and increases in a fan shape (linear). The recharging energy also increases in linear form and the output energy increases proportionally in a fan shape. This shows the possibility of linear variables in the single pulse output energy of a transcranial magnetic stimulation by controlling the number of switches. The recharging voltage increases with increasing number of switches. This leads to increased energy, resulting in an increase in the peak electric current. The single pulse output energy of the transcranial magnetic

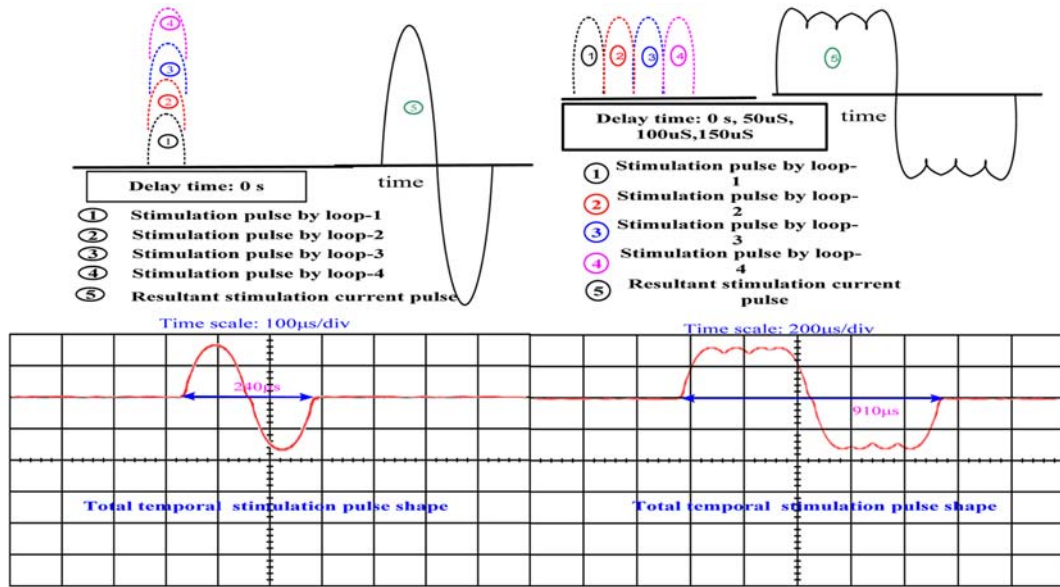

Fig. 7. (Color online) Stimulating coil waveform; when the stimulating coil waveform triggers 4 steps simultaneously, the first current waveform is presented, and the second waveform is then presented with a time delay.

stimulation also increases. The half amplitude of the current pulse (FWHM) is $125 \mu\text{s}$, showing consistency, as the pulse shaping inductor, L_M , was left consistent, and only the recharging voltage was changed.

As the pulse repetition rate in Hz increases, the peak value of the electrical current decreases slightly, which inhibits the effects of the transcranial magnetic stimulation single pulse as the pulse repetition rate becomes high. The output curve of the transcranial magnetic stimulation decreases gradually with increasing pulse repetition rate. Fig. 8 shows the output characteristics of the transcranial magnetic stimulation as a function of the switching and

pulse repetition rate. The output was varied between 0 and 421 W. The number of switching and pulse repetition rate can be controlled simultaneously, and the output of the transcranial magnetic stimulation can be controlled accurately when these two values are adjusted because any output value within the curve can be generated.

4. Conclusion

This study constructed a small sized transcranial magnetic stimulation because it does not employ a booster transformer, can recharge the rectified direct current by changing the energy storing condenser from 0 to 1,620 V by using resonance current type half wave bridge inverter and Cockcroft-Walton circuit, and can be adjusted with a pulse repetition rate Hz. The condenser recharging voltage, energy, and output energy of the single pulse transcranial magnetic stimulation can also be changed into a linear form when the number of switches in the half wave bridge inverter is adjusted. Therefore, the output of the transcranial magnetic stimulation can be varied accurately by controlling the output energy of a single pulse transcranial magnetic stimulation based on an adjustment of the switching frequency. Moreover, the pulse repetition rate can be adjusted simultaneously.

Acknowledgement

This work was supported by the Dong-A University Research Fund.

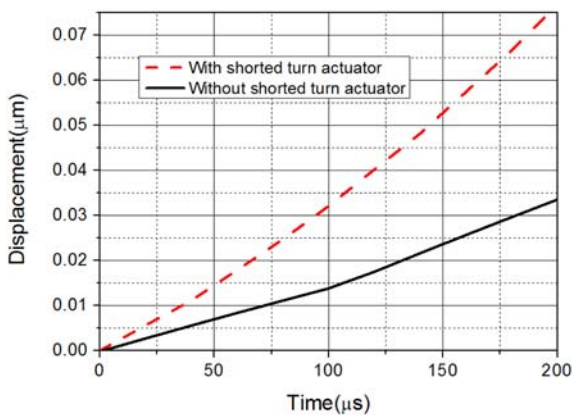

Fig. 8. (Color online) Condenser recharging voltage based on the number of switches, the correlation between its recharging energy and the output energy of the single pulse transcranial magnetic stimulation.

References

- [1] Orrin Devinsky, Aleksandar Beric, and Michael Dogali, *Electrical and Magnetic Stimulation of the Brain and Spinal Cord*, Raven Press, New York (1993).
- [2] E. Wassermann, *Oxford handbook of Transcranial magnetic stimulation*, Oxford University Press, Oxford (2007).
- [3] S. S. Choi, *J. Magnetism* **16**, 246 (2011).
- [4] Richard S. J. Frackowiak, John T. Ashburner, William D. Penny, Semir Zeki, Karl J. Friston, Christopher D. Frith, Raymond J. Dolan, and Cathy J. Price, *Human Brain Function*, 2nd Ed., Academic Press, New York (2004).
- [5] V. Walsh and A. Pascual-Leone, *Transcranial Magnetic Stimulation: a Neurochronometrics of Mind*, The MIT Press, Cambridge (2005).
- [6] Mark S. George and Robert H. Belmaker, *Transcranial Magnetic Stimulation in Clinical Psychiatry*, American Psychiatric Publishing, Inc., London (2006).
- [7] A. L. Nicole, *The Statistical Analysis of Functional MRI Data*. Springer, Berlin (2008).
- [8] Walter J. Levy, Roger Q., M. D. Cracco, Anthony T. Barker, and J. C. Rothwell, *Magnetic Motor Stimulation: Basic Principles and Clinical Experience*, Elsevier Science, Oxford (1991).
- [9] Carl Senior, Tamara Russell, and Michael S. Gazzaniga, *Methods in Mind*, The MIT Press, Cambridge (2006).
- [10] D. H. Ha, *J. Magnetism* **16**, 234 (2011).